



# **Alpha 160A Flight Manual**

Alpha Aviation Design Ltd retains copyright on this document. This document may not be reproduced in whole or in part in any form or by any means without the prior written permission of the Chief Executive.

**Page Intentionally Left Blank**

**PILOTS OPERATING HANDBOOK  
AND  
CIVIL AVIATION AUTHORITY OF NEW ZEALAND  
APPROVED FLIGHT MANUAL AIR 3001  
FOR THE  
ALPHA 160A  
(TYPE CERTIFICATE MODEL R2160)**

Manufacturer's Serial No:

Registration:

Type Certificate No: A-15

**THIS HANDBOOK INCLUDES THE MATERIAL REQUIRED TO BE FURNISHED TO THE PILOT BY THE CIVIL AVIATION AUTHORITY OF NEW ZEALAND AND ADDITIONAL INFORMATION PROVIDED BY THE MANUFACTURER, AND CONSTITUTES THE CIVIL AVIATION AUTHORITY OF NEW ZEALAND APPROVED AIRPLANE FLIGHT MANUAL.**

Civil Aviation Authority of New Zealand approved in the Acrobatic and Utility Category based on FAR 23. This document must be carried in the airplane at all times.

Accepted by: **FEDERAL AVIATION ADMINISTRATION  
EUROPEAN AVIATION SAFETY AGENCY**

Approved by: **CIVIL AVIATION AUTHORITY OF NEW ZEALAND**

By: S.A. Johnson (NAME)  MANAGER AEROBUSINESS (TITLE)

Date: 13 APR 17

Manufacturer's Name: ALPHA AVIATION MANUFACTURING LTD  
HAMILTON AIRPORT  
NEW ZEALAND  
Telephone: (64) 07 843 9877

**Page Intentionally Left Blank**

---

## Table of Contents

<b>Cover</b>	<b>i</b>
<b>Approval</b>	<b>iii</b>
<b>List of Revisions</b>	<b>vii</b>
<b>List of Effective Pages</b>	<b>ix</b>

---

<b>Section 1 :</b>	<b>General</b>	<b>1-1</b>
<b>Section 2 :</b>	<b>Limitations</b>	<b>2-1</b>
<b>Section 3 :</b>	<b>Emergency Procedures</b>	<b>3-1</b>
<b>Section 4 :</b>	<b>Normal Procedures</b>	<b>4-1</b>
<b>Section 5 :</b>	<b>Performance</b>	<b>5-1</b>
<b>Section 6 :</b>	<b>Weight and Balance</b>	<b>6-1</b>
<b>Section 7 :</b>	<b>Description of Aircraft &amp; Systems</b>	<b>7-1</b>
<b>Section 8 :</b>	<b>Handling, Servicing &amp; Maintenance</b>	<b>8-1</b>
<b>Section 9 :</b>	<b>Supplements</b>	<b>9-1</b>

**Page Intentionally Left Blank**



**Page Intentionally Left Blank**

## List of Effective Pages

<b>PAGE</b>	<b>DATE</b>	<b>PAGE</b>	<b>DATE</b>	<b>PAGE</b>	<b>DATE</b>
i	July 2016	3-5	Dec 2006	5-10	June 2006
ii	July 2016	3-6	June 2006		
iii	July 2016	3-7	June 2006	6-1	July 2016
iv	July 2016	3-8	Dec 2006	6-2	July 2016
v	July 2016	3-9	June 2006	6-3	July 2016
vi	July 2016	3-10	Dec 2006	6-4	July 2016
vii	July 2016			6-5	July 2016
viii	July 2016	4-1	June 2006	6-6	July 2016
ix	July 2016	4-2	June 2006	6-7	July 2016
x	July 2016	4-3	June 2006	6-8	July 2016
		4-4	June 2006		
1-1	Dec 2006	4-5	June 2006	7-1	Dec 2006
1-2	June 2006	4-6	June 2006	7-2	June 2006
1-3	June 2006	4-7	June 2006	7-3	June 2006
1-4	June 2006	4-8	June 2006	7-4	Dec 2006
1-5	June 2006	4-9	June 2006	7-5	June 2006
1-6	June 2006	4-10	June 2006	7-6	June 2006
1-7	June 2006	4-11	June 2006	7-7	June 2006
1-8	June 2006	4-12	Dec 2006	7-8	Dec 2006
1-9	June 2006	4-13	June 2006	7-9	June 2006
1-10	June 2006	4-14	June 2006	7-10	Dec 2006
1-11	Dec 2006	4-15	June 2006	7-11	Dec 2006
1-12	June 2006	4-16	Dec 2006	7-12	June 2006
		4-17	June 2006	7-13	June 2006
2-1	Dec 2006	4-18	June 2006	7-14	June 2006
2-2	Dec 2006	4-19	Dec 2006	7-15	June 2006
2-3	Dec 2006	4-20	June 2006	7-16	June 2006
2-4	Dec 2006			7-17	June 2006
2-5	Dec 2006	5-1	June 2006	7-18	June 2006
2-6	Dec 2006	5-2	June 2006	7-19	June 2006
2-7	Dec 2006	5-3	June 2006	7-20	June 2006
2-8	Dec 2006	5-4	June 2006	7-21	June 2006
		5-5	June 2006	7-22	June 2006
3-1	June 2006	5-6	June 2006	7-23	June 2006
3-2	June 2006	5-7	June 2006	7-24	June 2006
3-3	June 2006	5-8	Dec 2006	7-25	June 2006
3-4	Dec 2006	5-9	June 2006	7-26	June 2006

<b>PAGE</b>	<b>DATE</b>
7-27	Dec 2006
7-28	Dec 2006
7-29	Dec 2006
7-30	Dec 2006
8-1	June 2006
8-2	June 2006
8-3	June 2006
8-4	June 2006
9-1	July 2016
9-2	June 2006

# Section 1 : General

## Table of Contents

Overall Dimensions.....	1-4
Cabin Dimensions.....	1-4
Wings.....	1-4
Ailerons.....	1-4
Wing Flaps.....	1-4
Horizontal Stabilizer.....	1-5
Vertical Stabilizer.....	1-5
Landing Gear.....	1-5
Brakes.....	1-6
Power Plant.....	1-6
Fuel.....	1-7
Oil.....	1-7
Maximum Authorised Weights.....	1-8
List of Abbreviations.....	1-9
List of Radio Abbreviations.....	1-10
Conversion Factors.....	1-11
Barometric Pressure Conversion Table.....	1-12

**Page Intentionally Left Blank**

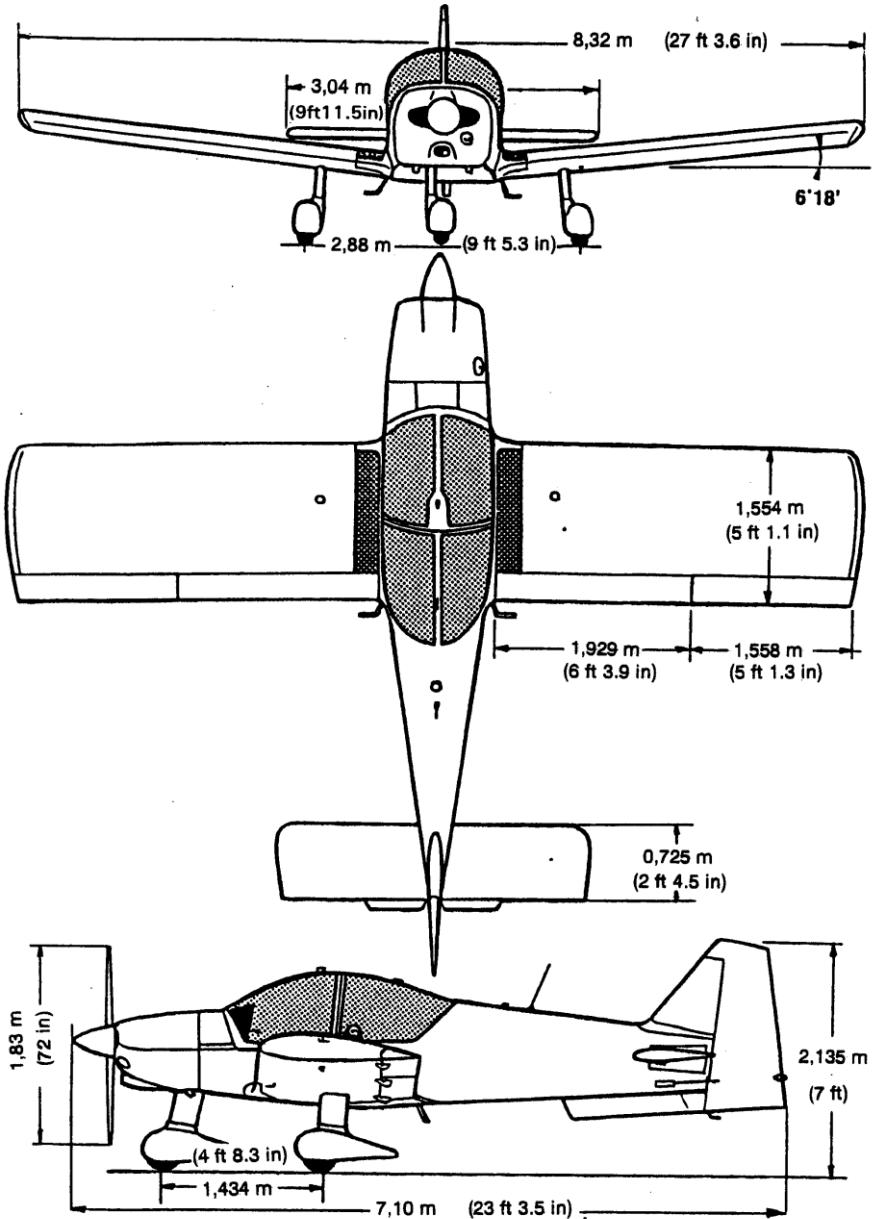

3 View Drawing



## Horizontal Stabilizer

Total control area .....	(25.2 sq ft) 2.35 m <sup>2</sup>
of which anti-balance tab .....	(2 x 0.6 sq ft) 2 x 0.063 m <sup>2</sup>
Span .....	(9ft11.5in) 3.04m
Deflection.....	up 10° (± 0.5°)
.....	down 12.5° (± 0.5°)
Anti-tab deflection:	
Elevator up .....	33° ± 3°, tab up
.....	5° ± 3°, tab down
Elevator down .....	14° ± 3°, tab up
.....	22° ± 3°, tab down

## Vertical Stabilizer

Surface overall .....	(16.5 sq ft) 1.53 m <sup>2</sup>
Stabilizer .....	(3.8 sq ft) 0.35 m <sup>2</sup>
Rudder.....	(12.7 sq ft) 1.18 m <sup>2</sup>
Deflection.....	0° to 30° (± 2.0°)

## Landing Gear

### Fixed Tricycle Type

Oleo-pneumatic dampers .....	stroke (6.3 in) 160 mm
Track.....	(9 ft 5.3 in) 2.88 m
Wheel base.....	(4 ft 8.3 in) 1.434 m
Tyre size .....	380 x 150
Oil/Air shock strut Hydraulic Oil.....	MIL H 5606-A

### Nose Gear

Tyre pressure.....	(23 psi) 1.6 bar
Shock strut pressure .....	(58 psi) 4 bar

**Main landing gear**

Tyre pressure.....(26 psi) 1.8 bar  
 Shock strut pressure. .... (116 psi) 8 bar

**Brakes**

The disc brakes are operated by an independent hydraulic circuit on each main gear wheel. Brakes can be applied by either pilot.

Hydraulic oil .....MIL H 5606-A

**Power Plant****Engine**

Manufacturer.....LYCOMING  
 Model..... 0-320-D2A  
 Type.....Horizontally opposed, 4 cylinders, normally aspirated  
 Maximum continuous power..... 160 HP at 2700 rpm  
 Maximum normal operating speed ..... 2600 rpm

**Propeller**

Manufacturer.....Sensenich  
 Model..... 74-DM-6S5-2-64  
 Diameter ..... 1.83 m (72 in)\*  
 Pitch.....1.62 m (64 in)  
 Type.....Fixed pitch, two bladed, metal  
 Minimum Static RPM, Full Throttle at sea level ..... 2150 rpm  
 Maximum RPM ..... 2700 rpm  
 Maximum normal operating speed ..... 2600 rpm

- **Any reduction in diameter during repair is forbidden**

## Fuel

Aviation petroleum<sup>1</sup> .....AVGAS 100 LL  
 Fuel grade<sup>1</sup> ..... (octane) 100 minimum

Single fuselage tank :

Total fuel capacity ..... (35.2 Imp. gal/42.2 US gal) 160 l  
 Total usable fuel .....(34.8 Imp. gal/41.7 US gal) 158 l  
 Unusable fuel..... (0.4 Imp. gal/0.5 US gal) 2 l

## Oil

Total engine capacity .....(8 US quarts) 7.5l  
 Usable capacity .....(6 US quarts) 5.7l

***During the first 50 hours of operation:***

***Use Only Pure mineral oil***

***After the first 50 hours of operation:***

***Dispersant oil***

## Grades<sup>2</sup>

Oil	Dispersant	Pure Mineral
All temperatures	SAE 15W50 or 20W50	.....
Above +25°C (80°F)	SAE 60	SAE60
Above +15°C (60°F)	SAE 40 or SAE 50	SAE50
From 0°C to +30°C (30°F to 90°F)	SAE 40	SAE40
From -15°C to +20°C (0°F to 70°F)	SAE 40, 30 or 20W40	SAE30
Below -10°C (10°F)	SAE30 or 20W30	SAE20

## Maximum Authorised Weights

	“U” category	“A” category
On take off	(1984 lb) 900kg	(1764 lb) 800kg
On landing	(1984 lb) 900kg	(1764 lb) 800kg

<sup>1</sup> Refer to the Service Instruction Lycoming n°1070 latest edition

<sup>2</sup> Refer to Service Instruction Lycoming 1014 latest edition.

## List of Abbreviations

sq ft.....	Square foot
ft .....	Foot
in.....	Inch
nm.....	Nautical mile
km.....	Kilometre
m.....	Meter
cm.....	Centimetre
kt.....	Knot
m/s.....	Meter per second
rpm .....	Revolution per minute
Va .....	Manoeuvring speed
Vc .....	Design cruise air speed
Vfe .....	Maximum Flaps extended speed
Vne .....	Never exceed speed
Vno .....	Maximum cruising speed
Vso .....	Stalling speed flaps in landing position
Vs1 .....	Stalling speed flaps up configuration
Vi .....	Indicated airspeed
Km/h .....	Kilometre per hour
HP.....	Horse power
hPa .....	Hectopascal
in.Hg .....	Inch of mercury
mbar .....	Millibar
Zp .....	Pressure altitude
l.....	Litre
imp gal .....	Imperial gallon
us gal .....	US gallon
psi.....	Pound per square inch
lb.....	Pound
kg.....	Kilogram
°C.....	Degrees Celsius
°F .....	Degrees Fahrenheit
V .....	Volt
A .....	Ampere

## List of Radio Abbreviations

ADF .....	Automatic Direction Finder
ATC .....	Air Traffic Control
COM .....	Communication Transceiver
DME.....	Distance Measuring Equipment
ELT.....	Emergency Locator Transmitter
IFR.....	Instrument Flight Rules
ILS .....	Instrument Landing System
MKR.....	Marker Beacon Receiver
NAV .....	Navigation Indicator and Receiver
AUDIO .....	Audio Control Panel
VFR .....	Visual Flight Rules
VHF .....	Very High Frequency
VOR.....	VHF Omni-Range (beacon)

## Conversion Factors

nautical mile.....	x.....	1.852 .....	= .....	kilometres
feet.....	x.....	0.305 .....	= .....	metres
inches .....	x.....	0.0254 .....	= .....	metres
inches .....	x.....	25.4 .....	= .....	millimetres
feet/minute .....	x.....	0.00508 .....	= .....	metre/second
gallons (US) .....	x.....	3.785 .....	= .....	litres
gallons (Imp) .....	x.....	4.546 .....	= .....	litres
quarts (US) .....	x.....	0.946 .....	= .....	litres
knots .....	x.....	1.852 .....	= .....	km/h
psi .....	x.....	0.0689 .....	= .....	bar
in.Hg .....	x.....	33.86 .....	= .....	mbar
lb.....	x.....	0.453 .....	= .....	kg
ft.lb.....	x.....	0.138 .....	= .....	kg.m
(°F-32) .....	x.....	5/9 .....	= .....	°C

kilometres .....	x.....	0.539 .....	= .....	nautical mile
meters.....	x.....	3.281 .....	= .....	feet
meters.....	x.....	39.37 .....	= .....	inches
millimetres.....	x.....	0.03937 .....	= .....	inches
meter/second .....	x.....	197 .....	= .....	feet/minute
litres .....	x.....	0.264 .....	= .....	gallons (US)
litres .....	x.....	0.220 .....	= .....	gallons (Imp)
litres .....	x.....	1.057 .....	= .....	quarts (US)
km/h.....	x.....	0.539 .....	= .....	knots
bar .....	x.....	14.51 .....	= .....	psi
mbar .....	x.....	0.02953 .....	= .....	in.Hg
kg.....	x.....	2.205 .....	= .....	lb
kg.m.....	x.....	7.234 .....	= .....	ft.lb
°C.....	x.....	9/5 + 32 .....	= .....	°F

## Barometric Pressure Conversion Table

Below pressure in MILLBAR or HECTOPASCAL, the pressure in INCHES of MERCURY is indicated.

→ mbar or hPa  
in.Hg

950 28.0	960 28.3	970 28.6	980 28.9	990 29.2	1000 29.5	1010 29.6	1020 30.1	1030 30.4	1040 30.7
951 28.0	961 28.3	971 28.6	981 28.9	991 29.2	1001 29.5	1011 29.8	1021 30.1	1031 30.4	1041 30.7
952 28.1	962 28.4	972 28.7	982 29.0	992 29.2	1002 29.5	1012 29.8	1022 30.1	1032 30.4	1042 30.7
953 28.1	963 28.4	973 28.7	983 29.0	993 29.3	1003 29.6	1013 29.9	1023 30.2	1033 30.5	1043 30.8
954 28.1	964 28.4	974 28.7	984 29.0	994 29.3	1004 29.6	1014 29.9	1024 30.2	1034 30.5	1044 30.8
955 28.2	965 28.5	975 28.7	985 29.0	995 29.3	1005 29.6	1015 29.9	1025 30.2	1035 30.5	1045 30.8
956 28.2	966 28.5	976 28.8	986 29.1	996 29.4	1006 29.7	1016 30.0	1026 30.3	1036 30.5	1046 30.8
957 28.2	967 28.5	977 28.8	987 29.1	997 29.4	1007 29.7	1017 30.0	1027 30.3	1037 30.6	1047 30.9
958 28.2	968 28.5	978 28.8	988 29.1	998 29.4	1008 29.7	1018 30.0	1028 30.3	1038 30.6	1048 30.9
959 28.3	969 28.6	979 28.9	989 29.2	999 29.5	1009 29.8	1019 30.0	1029 30.3	1039 30.6	1049 30.9

### Reminder:

The standard pressure of 1013.2 mbar or hPa equals 29.92 in.Hg.



## Section 2 : Limitations

### Table of Contents

Certification Standards.....	2-3
Approved Operation.....	2-3
Flight Load Factor Limits at Maximum Weight.....	2-4
Weight & Balance Envelope.....	2-4
Engine Limitations.....	2-5
Tachometer Markings .....	2-5
Fuel.....	2-5
Oil .....	2-5
Cylinder Head Temperatures .....	2-6
Payload Limits .....	2-6
Operational Limits In “U” Category.....	2-6
Low Temperature Operations .....	2-6
Operation Placards .....	2-7

**Page Intentionally Left Blank**

## Certification Standards

The R2160A aircraft has been certified in the “ACROBATIC” and “UTILITY” categories conforming to the following technical conditions:

- Standard technical conditions: FAR 23, Amendments 1 to 9 included
- Complimentary conditions AIR 2052, 3.397 and 3.399
- Special condition: the canopy must be jettisonable.

### NOTE

All speeds in this manual are indicated airspeeds unless otherwise specified.

## Approved Operation

VFR by day & night in non-icing conditions.

AIRSPEED LIMITATIONS	kt	km/h
Vne (never exceed)	178.5	331
Vno (max. cruise)	127	236
Va (max. manoeuvre)	127	236
Vfe (max. flaps extended)	97	180

AIRSPEED INDICATOR MARKINGS		kt	km/h
Red line (never exceed)	$V_{ne}$	178.5	331
Yellow arc (operate with caution and only in “smooth air”)	$V_{no}-V_{ne}$	127-178.5	236-331
Green arc (normal operating range)	$V_{s1}-V_{no}$	63-127	117-236
White arc	$V_{so}-V_{fe}$	51-97	94-180

## Flight Load Factor Limits at Gross Weight

	"U" category	"A" category
Flaps up	+ 4.4 g -1.76 g	+ 6 g -3 g
Flaps down	+2 g	+2 g

## Maximum Authorised Weights

	"U" category	"A" category
On take off	(1984 lb) 900kg	(1764 lb) 800kg
On landing	(1984 lb) 900kg	(1764 lb) 800kg

## Weight and Balance Envelope

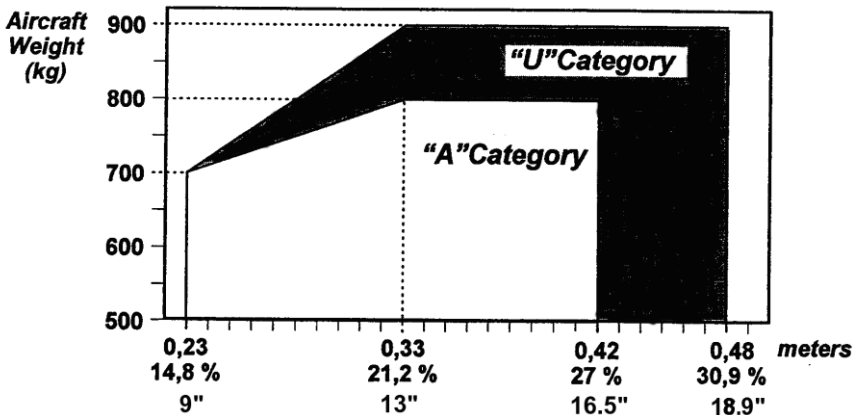

Levelling ..... upper fuselage longeron  
 Datum ..... leading edge at rib n°5  
 Chord ..... (61.2 in) 1.554 m

### NOTE

It is the responsibility of the aircraft owner and the pilot to ensure that the aircraft is properly loaded. See Section 6 Weight & Balance for proper loading instructions.

## Engine Limitations

Continuous starter operation .....	15 to 20 sec.
Maximum rpm (red line) .....	2700 rpm
Maximum Normal Operating .....	2600 rpm

## Tachometer Markings

Green arc.....	2300 to 2600 rpm
Red line .....	2700 rpm

## Fuel

Aviation petroleum <sup>3</sup> .....	AVGAS 100 LL
Fuel grade <sup>3</sup> .....	(octane) 100 minimum
Total fuel capacity .....	(35.2 Imp. gal/42.2 US gal) 160 l
Total usable capacity .....	(34.8 Imp. gal/41.7 US gal) 158 l
Unusable fuel.....	(0.4 Imp. gal/0.5 US gal) 2 l
Normal pressure .....	0.5 to 5 psi

## Oil

Maximum temperature (red LED).....	(245°F) 118°C
Normal temperature (green LED).....	(140 to 245°F) 60 to 118°C
Minimal idle pressure (red LED).....	25 psi
Yellow arc .....	25 to 55 psi
Normal pressure (green LED) .....	55 to 95 psi
Yellow LED (ground warm up) .....	95 to 115 psi
Maximum pressure cold start and take-off (red LED) .....	115 psi

<sup>3</sup> Refer to Service Instruction Lycoming n<sup>o</sup> 1070 latest edition.

## Cylinder Head Temperatures

Maximum temperature ..... (500°F) 260 °C  
 Normal Operating temperature range..... (150 to 435°F) 66 to 224°C

## Payload Load Limits

Number of occupants ..... 2  
 Maximum authorized weight of baggage (in Utility Category ONLY)(77 lb) 35 kg

## Operational Limits In “U” Category

Within the limits of this category, the following manoeuvres are authorized:

Turn at more than 60° bank.....entry speed 108 kt (200 km/h)  
 Lazy eight .....entry speed 130 kt (240 km/h)  
 Chandelle.....entry speed 130 kt (240 km/h)

## Low Temperature Operations

The aircraft can be used down to a temperature of -25 C (-13 F) on the ground.

Refer to oil grade chart on page 1-7 when operating at low temperatures.

When ambient air temperatures less than 5°C or if the oil temperature remains below 80°C for sustained periods it is recommended that the winterisation plate P/N 54.23.17.010 is fitted to the oil cooler in accordance with the maintenance manual.

## Operation Placards

In full view of the pilot

INVERTED FLIGHT PERMITTED FOR 20 SECONDS ONLY	SPINNING IS FORBIDDEN IN UTILITY CATEGORY	MAX. FUEL 120 Litres (37.5 US gal) IN ACROBATIC CATEGORY	G.P.S NOT APPROVED FOR I.F.R FLIGHT
--	--	--	--

On annunciator panel

MAX MANOEUVRING SPEED: 127 kt-236km/h	INVERTED SPINNING PROHIBITED	VFR FLIGHT BY DAY AND NIGHT IN NON-ICING CONDITIONS	THIS AIRCRAFT MUST BE USED IN ACROBATIC OR UTILITY CATEGORY, IN ACCORDANCE WITH THE APPROVED FLIGHT MANUAL	ON THIS AIRCRAFT, ALL PLACARDS CORRESPOND TO ACROBATIC UTILIZATION, FOR UTILITY OPERATION, REFER TO THE APPROVED FLIGHT MANUAL.	NO SMOKING
--	------------------------------------	---	---	--	---------------

On instrument panel above ASI & AH

<u>ACROBATIC CATEGORY</u> <u>APPROVED MANOEUVRES</u>	
SPIN (FLAPS UP).....	54 KIAS
POSITIVE LOOP.....	130 KIAS
ROLL.....	108 KIAS
STALL TURN.....	120 KIAS
45° HALF ROLL & DIVE OUT.....	120 KIAS
CHANDELLE.....	120 KIAS
HALF LOOP & ROLL OUT.....	135 KIAS
FLICK ROLL.....	86 KIAS
LAZY EIGHT.....	120 KIAS
<u>SPIN RECOVERY PROCEDURE</u>	
FULL OPPOSITE RUDDER	
ELEVATOR CONTROL NEUTRAL	
AILERON NEUTRAL	

On sub panel adjacent to vacuum gauge

NO BAGGAGE ALLOWED DURING ACROBATIC FLIGHT
MAXIMUM BAGGAGE LOAD
<b>35kg (77 lb)</b>
REFER FLIGHT MANUAL

On baggage compartment aft bulkhead

<b>AUX. PWR.</b>
<b>12 V</b>
<b>5 AMP MAX</b>

On instrument panel by socket

<b>FUEL SHUT OFF</b>
<b>LIFT GUARD</b>
<b>PULL CONTROL KNOB</b>

Adjacent to control knob

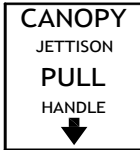

Adjacent to jettison handle  
on canopy over head frame

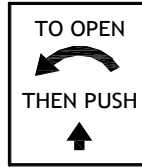

Adjacent to canopy handle

**CANOPY RELEASE (PULL) →**

On each of the canopy release handles

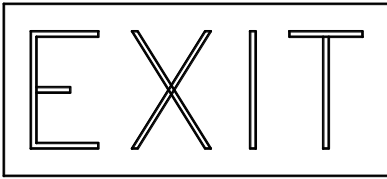

On bottom aft of Sliding Canopy (internal and external)

### External fuselage



Adjacent to refuelling receptacle

# **Section 3 :   Emergency                           Procedures**

## **Table of Contents**

Engine Failure During Take-Off Roll.....	3-3
Engine Failure Immediately After Take-Off.....	3-3
Engine Failure In Flight .....	3-4
Power Off Forced Landing Off Airfield.....	3-4
Precautionary Power Landing Off Airfield.....	3-5
Fire .....	3-5
Vibrations and Rough Engine Operation .....	3-7
Low Oil Pressure.....	3-7
Canopy Jettison .....	3-7
Icing.....	3-8
Electrical Power Supply Malfunction .....	3-9
Inadvertent Spin.....	3-10
Loss of Elevator Control.....	3-10

**Page Intentionally Left Blank**





## Precautionary Power Landing Off Airfield

Fly over the chosen field several times at low speed, 78 kt (145 km/h) for 800 kg or 83 kts (154 km/h) for 900 kg, in order to locate the most suitable landing area, flaps in “take-off” position (10°), then make a precautionary approach at, 66 kt (122 km/h) for 800 kg or 71 kt (131 km/h) for 900 kg, flaps in “landing” position (35°).

On final, unlock the canopy.

### Before touchdown

Magneto switch ..... OFF  
 Battery switch ..... OFF

### **NOTE: IN CASE OF CANOPY JAMMING**

*Canopy handle in “open” position.*

*Remove the safety locking device from central Jettison Handle.*

*Pull handle down and aft.*

**OR**

*Free the two canopy release levers located on the arm rests, on both sides of the instrument panel, and place them in vertical position activating the canopy jettison system.*

*Canopy should be reinstalled in accordance with the aircraft service manual.*

## Fire

### Engine fire during starting

Keep the engine turning with starter:

Fuel shut off control ..... pull out  
 Electric fuel pump ..... OFF  
 Throttle ..... full power (push)  
 Mixture ..... off (pull out)

The aim of this procedure is to make the engine “swallow” the accumulated fuel in the inlet pipes (generally following an excess of fuel priming during a difficult engine start).

**If the fire continues**

Magneto switch ..... OFF

Battery switch ..... OFF

Alternator switch ..... OFF

Abandon the aircraft and try to extinguish the fire with the aids available: fire extinguishers, covers, clothing or sand.

**Engine fire in flight**

Fuel shut off control ..... pull out

Throttle ..... full power until engine stops

Mixture ..... off (pull out)

Electric fuel pump ..... OFF

Alternator switch ..... OFF

Cabin heat and ventilation ..... off

Speed ..... 86 kt (160 km/h)

Prepare for a forced landing off airfield, following the procedures in the chapter "Power off forced landing off airfield"

Do not attempt to restart the engine.

**Cabin Fire**

Extinguish the fire by all means possible (optional extinguisher).

To eliminate smoke, apply maximum ventilation.

In case of an electrical fire (fumes indicating insulation burning):

Cabin ventilation ..... reduce

Alternator switch ..... OFF

Battery switch ..... OFF

Battery circuit breaker ..... pull out

Alternator circuit breaker ..... pull out

Land immediately if the fire continues.

**Vibration and Rough Engine Operation**

Vibrations and rough engine operation are generally due to (verify in this order):

- Carburettor icing: see paragraph "ICING" on next page.
- Mixture set too rich or too lean: adjust the mixture (see section 4)

- Contamination in the fuel system: verify fuel pressure. Switch on the electric fuel pump
- Ignition failure: magneto switch on “L”, then “R”, then return to “BOTH”. Select the position providing the best engine operation and fly to the nearest airfield, at reduced power and mixture set to obtain the smoothest engine operation possible.

### **Low Oil Pressure**

In case of low oil pressure indication, check oil temperature and if it is too high (red arc):

- Reduce power  
If oil pressure does not recover:-
- Fly to the nearest airfield, and/or prepare for an off airfield landing.

### **Canopy Jettisoning**

Remove the safety locking device from central Jettison Handle

Pull handle down and aft.

If the central jettison handle fails.

Free the two canopy release levers located on the arm rests, on both sides of the instrument panel, and place them in vertical position activating the canopy jettison system.

Push canopy up

## Icing

Although it is forbidden to fly in icing conditions, proceed as follows when inadvertently encountering icing:

- Carburettor heat on (pull)
- Increase power in order to reduce ice build-up to minimum
- Switch on pitot heat (if installed)
- Select maximum cabin heat and direct the total output to the windscreen (“defrost” position) in order to remove the ice quickly
- Turn back or change altitude, to obtain an outside air temperature less conducive to icing
- Plan to land at the nearest airfield.
- Do not use the flaps

With an extremely rapid ice build-up, carry out a forced landing.

Remember that a layer of 0.5 cm (0.2 in) on the wing leading edge will increase stall speed. If needed, use a higher than normal approach speed: 139 to 150 km/h (75 to 81 kt).

### **REMARKS**

*If continuous carburettor heat is judged necessary, it is imperative to adjust the mixture control to obtain normal engine operation.*

*Always use carburettor heat fully on or fully off, in certain cases, an intermediate position could increase icing.*

## Electrical Power Supply Malfunction

Alternator failure is indicated when the red “ALT FAIL” warning light on the annunciator panel is lit. The “ALT FAIL” warning light indicates that the battery, rather than the alternator, is supplying power to the bus-bar.

### If the “ALT FAIL” warning light is on

Switch off the alternator, and then switch it back on.

This operation resets the overvoltage relay which may have cut-out due to a transient overvoltage.

#### **NOTE**

*Warning light may come on during low engine rpm. Check that increasing rpm makes the light go out.*

### If the “ALT FAIL” warning light remains on

- Switch off the alternator.
- Switch off all the electrical equipment not essential to the continuation of the flight.
- Land as soon as possible and have the electrical system inspected.

#### **NOTE**

*An alternator failure does not prevent the engine from operating normally.*

## Inadvertent Spin

Should a spin occur, use the following procedure:

Throttle ..... idle (pull)

Rudder ..... full opposite to direction of rotation

Elevator ..... forward to neutral

Ailerons ..... neutral

Once the rotation stops, rudder to neutral position and recover within flight limitations.

### **NOTE**

*If the flaps are down when the spin begins, retract them immediately.*

## Loss of Elevator Control

In case of a loss of elevator control (accidental disconnection):

- Stabilize the aircraft in level flight, flaps at 35°, at 75 kt (139 km/h), using the elevator trim and throttle.
- Do not change the elevator trim setting and control the angle of descent with throttle only. Reduce throttle only when in short final and near to the ground.

# Section 4 : Normal Procedures

## Table of Contents

Loading.....	4-3
Normal Operating Speeds.....	4-3
Pre-Flight Inspection .....	4-4
Cabin Interior Check Prior Start-Up.....	4-7
Before Starting Engine .....	4-7
Parking Brake Use .....	4-7
Starting the Engine .....	4-8
After Engine Start.....	4-9
Taxiing .....	4-9
Engine Run-Up .....	4-10
Before Take-Off .....	4-11
Take-Off.....	4-11
Climb .....	4-12
Cruise .....	4-13
Use of Carburettor Heater.....	4-14
Descent .....	4-15
Landing.....	4-16
After Landing .....	4-16
Engine Shut-Down .....	4-17
Acrobatic Flights .....	4-17

**Page Intentionally Left Blank**

## Loading

Before each flight, insure that the total weight and the load balance are within the established limits. For this, use the weight and balance chart in Section 6.

## Normal Operating Speeds

The speeds identified hereunder are indicated Airspeeds recommended for normal operations.

They are based on a standard aircraft, operated at gross weight, in standard atmosphere, at sea level. They can change from one aircraft to another, depending on the installed equipment, aircraft and engine condition, atmospheric conditions and pilot proficiency.

### Best rate of climb speed

Flaps in take-off position (10°).....	(800 kg) 75 kt (139 km/h)
	(900 kg) 79 kt (147 km/h)
Flaps up.....	(800 kg) 78 kt (145 km/h)
	(900 kg) 83 kt (154 km/h)

### Best angle of climb speed

Flaps in take-off position (10°) .....	(800 kg) 70 kts (130 km/h)
	(900 kg) 73 kts (135 km/h)
Flaps up.....	(800 kg) 73 kt (135 km/h)
	(900 kg) 78 kt (145 km/h)

### Maximum operating speed in turbulence

Flaps up.....	127 kt (235 km/h)
---------------	-------------------

### Maximum speed

Flaps in landing position (35°) .....	97 kt (180 km/h)
---------------------------------------	------------------

### Landing speed, final approach

Flaps in landing position (35°) .....	(800 kg) 65 kt (120 km/h)
	(900 kg) 70 kt (130 km/h)

## Pre-Flight Inspection

To be performed before each flight.

This inspection may be reduced after intermediate en route landings.

Magneto switch ..... OFF

Controls ..... free

Control surface deflections..... check

Battery switch ..... ON

Flaps..... check operation

Fuel quantity ..... check

Battery switch ..... OFF

Fuel shut off control: pushed in and cover closed..... check

Aircraft documents ..... check availability on board

Instruments ..... ensure all are in good condition

Baggage ..... check stowed

Make an aircraft walk-around inspection (as shown below) beginning at the fuselage left side.

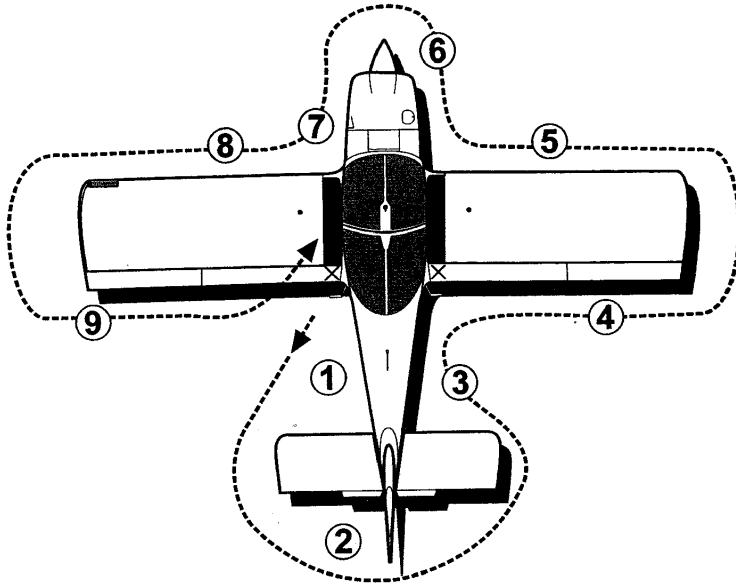





## Starting the Engine

### Normal procedure

Carburettor heat..... off (push in)  
 Mixture.....pushed full rich  
 Strobe light..... ON  
 Gauges..... check  
 Magneto switch.....on BOTH  
 Electric fuel pump ..... ON  
 Throttle ..... carry out 2 or 3 pumps, then  $\frac{1}{4}$  travel forward  
 Propeller area ..... clear  
 Starter..... turn and push on (15 to 20 sec. maxi.)

### Hot engine procedure

Same as “Normal procedure”, but without pumping throttle.

### Cold weather procedure (Below 5 C)

Same as “Normal procedure”, but keep pumping throttle up to 900 or 1000 rpm until engine runs smoothly.

### Engine “flooded”

Electric fuel pump ..... OFF  
 Mixture..... lean (pull out)  
 Throttle .....full power (push in)  
 Alternator ..... OFF  
 Starter..... operate for 10-15 seconds

As soon as the engine fires, reduce throttle to  $\frac{1}{4}$  and advance mixture control to “rich” and resume the normal procedure without pumping throttle.

***ATTENTION: Avoid operating the starter for more than 20 seconds. Wait at least a minute before operating it again.***

***As soon as the engine is running, check the engine oil pressure. If it is zero after 15 to 20 seconds, switch off and investigate the cause.***

## After Engine Start

RPM.....	1200
Electric fuel pump .....	OFF
Alternator switch .....	ON
Voltmeter .....	green range
Vacuum gauge .....	green range
Annunciator Lights .....	test and select brightness
Avionics Master .....	ON
COM/NAV, navigation instruments.....	set
Altimeter .....	set

## Taxiing

Parking brake.....	released
Brakes .....	test
Turn co-ordinator .....	check
Directional gyro .....	check setting

Avoid exceeding 1200 rpm while oil temperature is in yellow arc.

## Engine Run-Up

Parking brake..... applied  
Oil pressure and temperature..... green range  
Fuel pressure..... green range  
Mixture..... (full rich) in  
Carburettor heat..... off (push in)

### Magneto check

Throttle ..... 1800 rpm  
Magneto selection:  
Max. drop between “L” or “R” and “BOTH” ..... 175 rpm  
Max. difference between “L” and “R” ..... 50 rpm

### Carburettor heat check

Carburettor heat (at 1800 rpm)..... full on  
Check rpm drop ..... between 20 and 200 rpm  
Carburettor heat..... off (push in)

### Mixture check

Lean until rpm reduction, then return to “full rich”.

### Engine idle check

Throttle ..... 600 to 650 rpm



**Short field take-off**

Flaps..... (10°) take-off position

Apply full power, brakes applied,

then release the brakes ..... minimum 2150 rpm

Rotation speed..... (800 kg) 55 kts (102 km/h)

(900 kg) 58 kts (107 km/h)

Then, if necessary (to clear an obstacle)

Best angle of climb speed ..... (800 kg) 70 kts (130 km/h)

(900 kg) 73 kts (135 km/h)

**Crosswind take-off (greater than 12 kts crosswind)**

Flaps..... take-off position (10°)

Ailerons.....into the wind

Take-off at 10% higher airspeed than normal. Correct drift in the normal way (max bank angle close to the ground: 15°).

Demonstrated crosswind velocity: 18 kts (33 km/h)

**Climb****Normal climb (flaps up)**

Set speed for best rate of climb:

800 kg – 78 kts (145 km/h); 70 kts (130 km/h) at 10,000 ft.

900 kg – 83 kts (154 km/h); 75 kts (139 km/h) at 10,000 ft

Above 5 000 ft, adjust mixture.

**Best angle of climb**

The best angle of climb is obtained at,

800 kg - 73 kts (135 km/h) clean; 70 kts (128 km/h) flaps 10°

900 kg - 78 kts (145 km/h) clean; 73 kts (135 km/h) flaps 10°

**NOTE**

*This type of climb should only be used only as necessary, due to poor engine cooling.*

## Cruise

Refer to Section 5 for rpm setting and cruise performance.

### Operation of mixture control

Maintain mixture control in the “full rich” position during take-off and in the climb.

In certain conditions (high altitude take-off, or long climb above 5000 ft), this setting may be too rich and could result in irregular engine operation or loss of power.

In these cases, adjust the mixture to recover regular engine operation, and not for fuel economy.

#### **Mixture adjustment in stable cruise:**

Progressively lean the mixture until a slight reduction in rpm is noted; then lightly enrich to re-establish power and normal operation.

#### **NOTE**

*Take care not to lean the mixture too much, which would cause engine overheating.*

**ALWAYS ENRICH THE MIXTURE BEFORE INCREASING POWER.**

## Use of Carburettor Heater

### WARNING

Never keep the carburettor heater ON, when taking off.

If, while cruising at constant altitude and in smooth air, with a given power setting, there is a drop in rpm; or a reduction of the manifold pressure (on aircraft equipped with a manifold pressure gauge).

- Pull the carburettor heater control fully ON for 30 seconds
- Note the effect on rpm; or on the manifold pressure

If they increase the carburettor was beginning to ice up.

- Push OFF the carburettor heater and check that the initial engine parameters are recovered
- Repeat this operation at regular intervals, according to the meteorological conditions

Do not set the carburettor heater control in an intermediate position, as the action of the heater is not proportional to the travel of the control.

When landing in cold or damp weather, pull the carburettor heater control ON one or two minutes before closing the throttle.





## Engine Shut-Down

Park brake .....on  
 ELT .....Check not triggered  
 Avionics master ..... OFF  
 Electrical equipment.....off  
 Canopy ..... closed, locked  
 Magneto cut-off check at idle .....OFF then BOTH  
 RPM..... 1000  
 Mixture..... idle cut-off

### After the engine stops

Magneto switch ..... OFF  
 Alternator switch ..... OFF  
 Battery switch ..... OFF  
 When wheel chocks in place .....release the parking brake

## Acrobatic Flights

### IMPORTANT NOTES

- This aircraft is not provided with a fuel or oil system allowing sustained inverted flight.
- The lubrication does not take place while the aircraft is in the inverted position. An air-oil separator is provided to prevent the oil flowing through the engine breather.
- The luggage hold must be empty and no object may be loose in the cabin.
- Make sure that the aircraft C of G is within the permissible limits.

## Spinning

It is recommended to perform the spin in the following manner:

- Flaps must be retracted
- Start the spin at an adequate height above the safety altitude, taking into consideration that the loss of altitude is about 230 ft per revolution and that the final recovery takes about 1300 ft.
- Throttle back in level flight, decrease the speed with a slightly positive vertical position
- When close to the stalling point (54 kts):  
Pull the elevator control fully back, ailerons in neutral and simultaneously apply rudder in the direction of required rotation
- When 2 or 3 rotations have been completed, apply the following recovery procedure:  
Rudder in fully opposite direction, elevator control to neutral and ailerons in neutral
- When spin rotation stops, recover to normal flight taking care to remain within operating limits.

### Example to recovery from a LH spin

- Apply and maintain full Right rudder, ailerons in neutral
- Stick to neutral
- After 3 revolutions, recovery is performed in approximately three quarters of a revolution.

### **Only one action is important - Keep the rudder fully in opposite direction!**

- In a spin of more than 3 revolutions, the engine is likely to stall. This raises no difficulty: the propeller should wind mill once airspeed is restored and re-start the engine.  
(**Caution:** Engage starter only if propeller stops rotating.)
- With a 4 revolution (or more) spin, recovery is performed in 1 ½ revolutions.
- During the recovery phase, keep a watch on the A.S.I. and on the accelerometer, to keep within the operating limits.

<b>Authorized acrobatic figures</b>	<b>Initial speed</b>
Positive spin.....	54 kts
Positive loop .....	130 kts (240 km/h)
Roll.....	108kts (200 km/h)
Stall turn.....	120 kts (220 km/h)
45° half roll and dive out .....	120 kts (220 km/h)
Chandelle.....	120 kts (220 km/h)
Half loop and roll out.....	135 kts (250 km/h)
Flick roll.....	86 kts (160 km/h)
Lazy eight .....	120 kts (220 km/h)
Turns at more than 60° bank .....	108 kts (200 km/h)

<b>Authorized “U” category figures</b>	<b>Initial speed</b>
Chandelle.....	130 kts (240 km/h)
Lazy eight .....	130 kts (240 km/h)
Turns at more than 60° bank .....	108 kts (200 km/h)

Intentional spins are prohibited in utility category operations

If, during one of the figures the engine stops, it is preferable to close throttle during the recovery only. The above figures can be performed without causing the engine to stop and at a load factor not exceeding 4 g.

**INVERTED SPIN PROHIBITED.**

**Inverted flight**

Inverted flight is only permitted for up to 20 seconds.

In order to prevent engine roughness apply following procedure:

Entry Speed ..... 119 kts (220 km/h)

As aircraft becomes inverted..... close throttle

For 20 seconds only.....maintain speed above 80 kts (150 km/h)

After return to normal flight.....open throttle smoothly

All aircraft are fitted with an oil recuperation system and dry battery.

# Section 5 : Performance

## Table of Contents

Noise Limitation .....	5-3
Stall Speeds.....	5-3
Airspeed Installation Calibration.....	5-4
Take-Off Performance .....	5-5
Climb Performance .....	5-6
Climb Time/Climb Distance.....	5-7
Cruise Performance .....	5-8
Glide Performance .....	5-9
Landing Performance.....	5-10

**Page Intentionally Left Blank**

## Noise Limitation

The maximum acceptable noise level in accordance with ICAO annex 16, chapter 6, for the R2160 aircraft, at a certified gross weight of (1984 lb) 900 kg, is 72 dB(A)

The actual noise level determined under the ICAO criteria is 69.8 dB(A).

## Stall Speeds

Engine idling, Weight: 800 kg (1763 lb)	kt (km/h)		
	0°	30°	60°
Bank angle	0°	30°	60°
Flaps up	59 (110)	64 (119)	84 (156)
Flaps 10°, take off position	58 (107)	62 (114)	81 (151)
Flaps 35°, landing position	48 (87)	51 (95)	68 (125)

Engine idling, Weight: 900 kg (1984 lb)	kt (km/h)		
	0°	30°	60°
Bank angle	0°	30°	60°
Flaps up	63 (117)	68 (126)	89 (165)
Flaps 10°, take off position	61 (113)	66 (121)	86 (160)
Flaps 35°, landing position	51 (94)	55 (101)	72 (133)

## Airspeed Installation Calibration

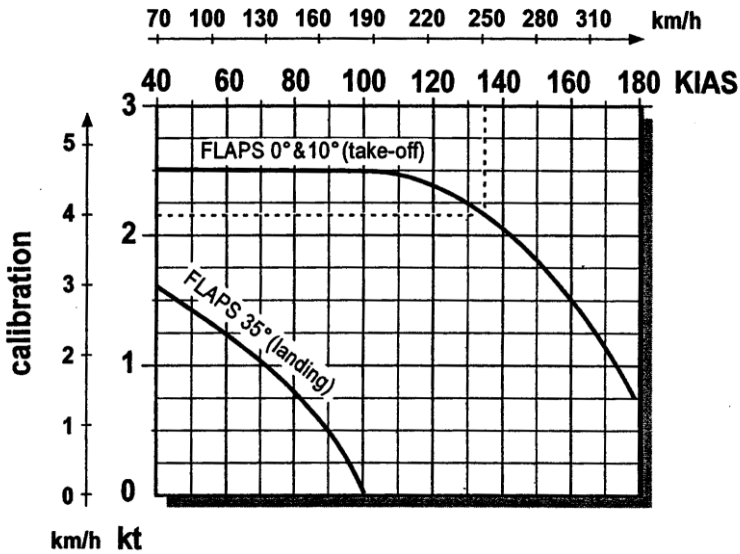

### Example

If KIAS is 135 kts (250 km/h), flaps up then KCAS will be 137 kts (254 km/h)

### NOTE

*All speeds in this manual are indicated airspeeds unless otherwise specified.*

## Take-Off Performance

Concrete level dry runway. Flaps in take-off position. Full throttle										
Max. weight kg (lb)	Head Wind (kt)	Sea level +15°C			2500 ft – (760 m) +10°C			5000 ft – (1525 m) +5°C		
		Run	15 m (5 clear		Run	15 m (5 clear		Run	15 m (5 clear	
		m (ft)	m (ft)		m (ft)	m (ft)		m (ft)	m (ft)	
900 (1984)	0	320 (1050)	574 (1883)		400 (1312)	700 (2297)		490 (1608)	870 (2854)	
	10	224 (735)	476 (1562)		280 (919)	590 (1936)		340 (1115)	730 (2395)	
	20	147 (482)	385 (1263)		180 (590)	470(1542)		224 (735)	590 (1936)	
800 (1744)	0	230 (754)	410 (1345)		285 (935)	500 (1640)		350 (1148)	620 (2034)	
	10	160 (525)	340 (1115)		200 (656)	420 (1378)		245 (804)	520 (1706)	
	20	105 (344)	275 (902)		130 (427)	335 (1099)		160 (525)	420 (1378)	
700 (1543)	0	160 (525)	285 (935)		200 (656)	350 (1148)		245 (804)	430 (1410)	
	10	110 (361)	240 (787)		140 (459)	290 (951)		170 (558)	360 (1181)	
	20	70 (230)	190 (623)		90 (295)	235 (771)		110 (361)	290 (951)	

- Increase distances by 8% for every 10°C increase of the standard temperature, at the appropriate altitude concerned.
- Take-off from dry grass runway: add 8%.

## Climb Performance

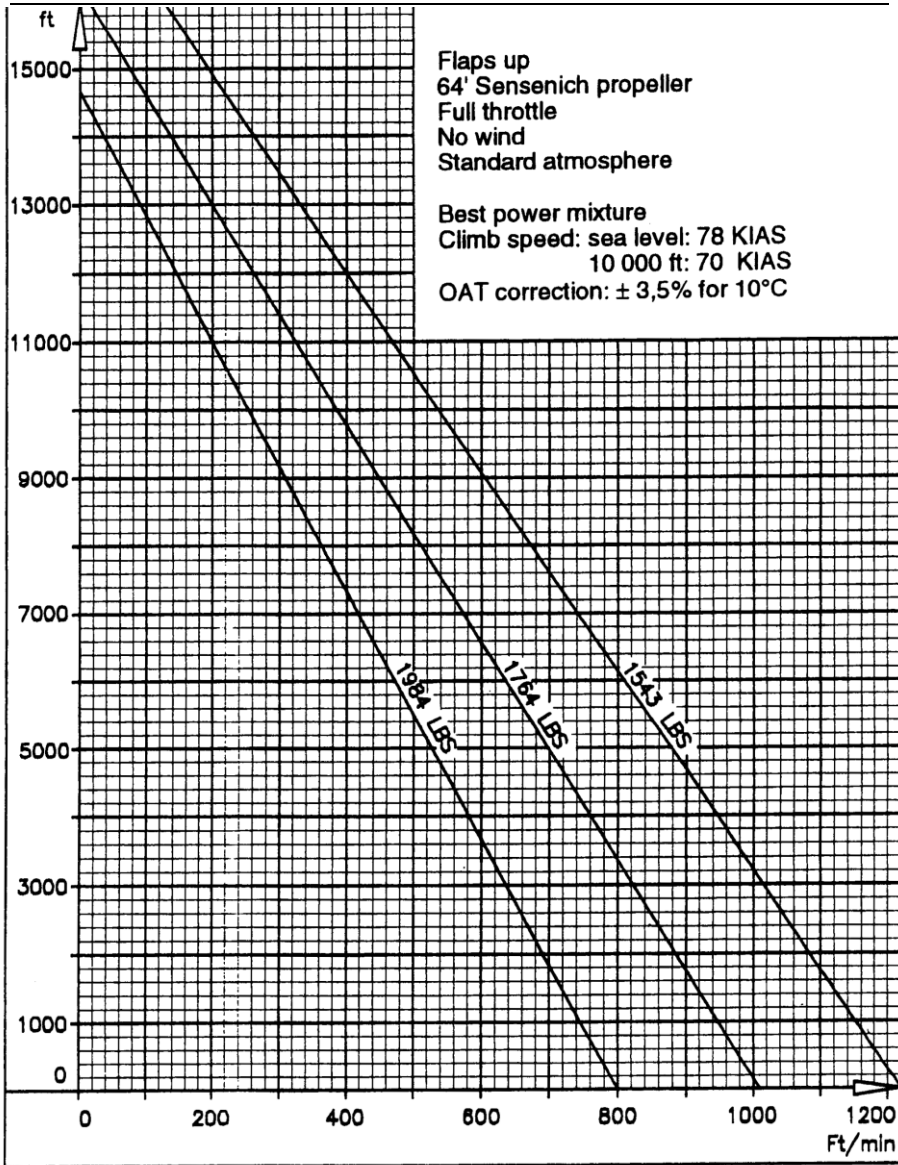

## Climb Time/Climb Distance

Standard atmosphere

Flaps up

Full throttle

MTOW 800 kg

Climb speed (IAS): 78 kt (145Km/h)

Consumption 30 l/h

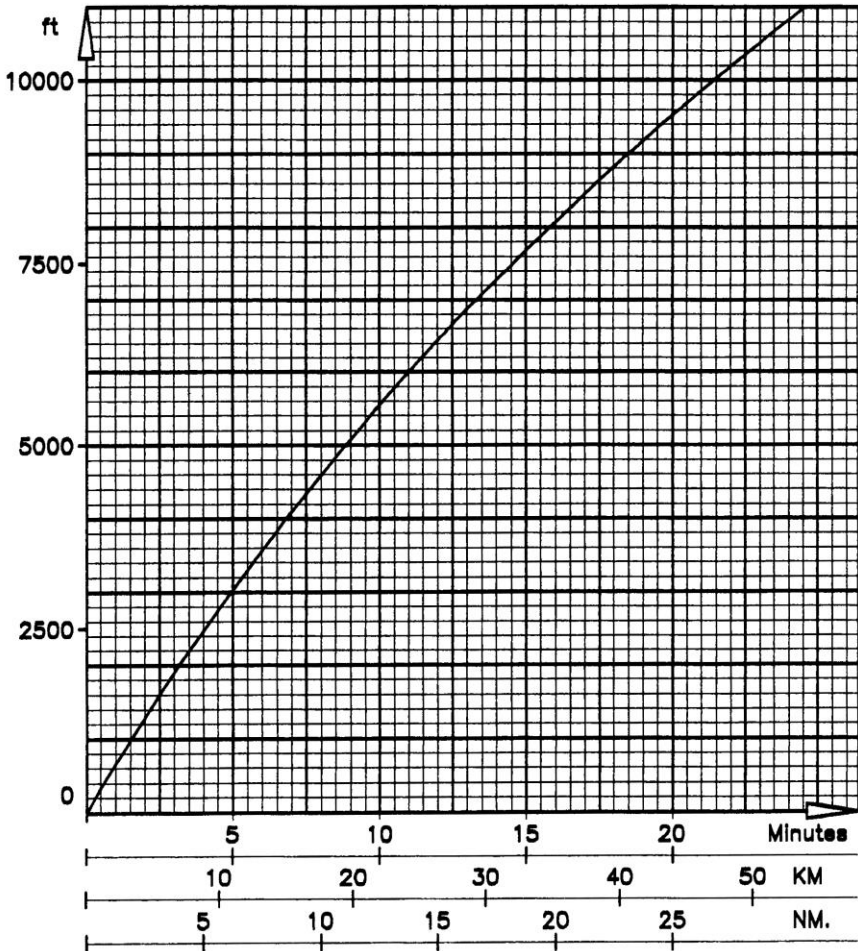

## Cruise Performance

MTOW 900 kg (1984 lb)

Flaps up

Standard atmosphere

No wind

Mixture at best power setting

Altitude ZP ft	Power		True Air Speed Kt (km/h)	Fuel Consumpt l/h (us gal)	Endurance H:min	Range	
	%	RPM				Km	Nm
SEA LEVEL	7	2550	116 (215)	35 (9.2)	4:30	965	520
	6	2450	111 (206)	30 (7.9)	5:15	1080	580
3000	7	2625	121 (224)	35 (9.2)	4:30	1010	540
	6	2525	116 (215)	30 (7.9)	5:15	1125	600
5500	7	2650	125 (232)	35 (9.2)	4:30	1040	560
	6	2550	119 (220)	30 (7.9)	5:15	1155	620
7500	7	2675 (*)	126 (233)	32 (8.7)	4:55	1150	620
	6	2600	122 (226)	30 (7.9)	5:15	1185	640

(\*) full throttle

## Glide Performance

Airspeed ..... (800 kg) 78 kt (145 km/h)  
 (900 kg) 83 kt (154 km/h)

Propeller ..... windmilling

Flaps ..... up

Without wind

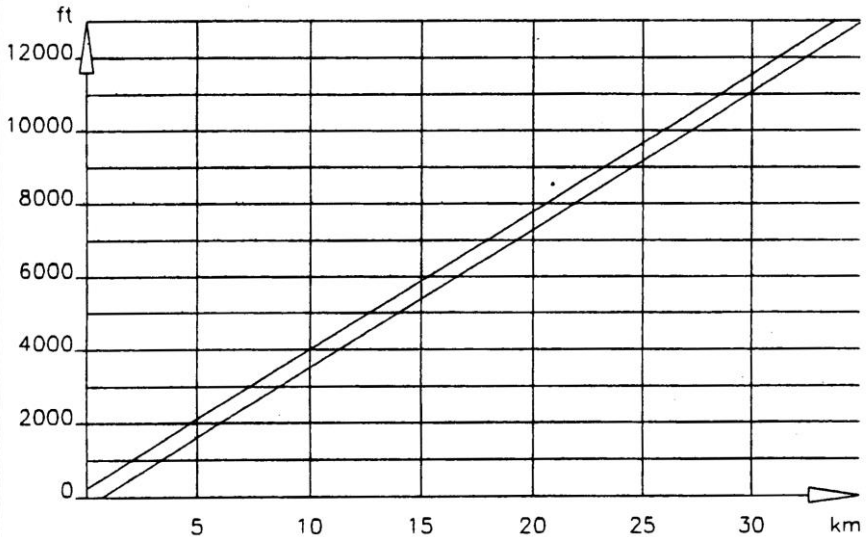

**Altitude and temperature do not have a noticeable influence.**

In wind-less conditions, with engine off, flaps up, propeller spinning and  $V_i = 78$  kt (145 km/h), the aircraft will glide over a distance equal to 8.7 times the altitude. Altitude and temperature have no substantial effect.

## Landing Performance

Dry, hard runway, flaps 35°, power off								
Max weight kg (lb)	Head Wind (kt)	Sea level +15°C		2500 ft – 760 m +10°C		5000 ft – 1525 m +5°C		
		Run	Distance to 15 m (50 ft)	Run	Distance to 15 m (50 ft)	Run	Distance to 15 m (50 ft)	
		m (ft)	m (ft)	m (ft)	m (ft)	m (ft)	m (ft)	
900 (1984)	0	233 (764)	440 (1444)	250 (820)	465 (1526)	265 (869)	490 (1607)	
	10	165 (541)	365 (1197)	175 (574)	390 (1279)	185 (607)	413 (1355)	
	20	120 (394)	295 (968)	130 (426)	310 (1017)	140 (459)	335 (1099)	
800 (1743)	0	220 (722)	415 (1361)	235 (771)	440 (1443)	250 (820)	465 (1525)	
	10	155 (508)	345 (1132)	165 (541)	370 (1214)	175 (574)	390 (1279)	
	20	115 (377)	280 (918)	125 (410)	295 (968)	130 (426)	315 (1033)	
700 (1543)	0	190 (623)	375 (1230)	205 (672)	400 (1312)	215 (705)	420 (1378)	
	10	135 (443)	315 (1033)	145 (476)	335 (1099)	150 (492)	350 (1148)	
	20	100 (328)	250 (820)	110 (361)	270 (886)	115 (377)	280 (918)	

Landing on grass runway: increase distances by 20%.

Approach speed: 65 kt (120 km/h)

Touch-down speed: 58 kt (107 km/h)

# **Section 6 : Weight and Balance**

## **Table of Contents**

Use of Weight and Balance Table..... 6-4

Fitted Equipment List ..... 6-7

**Page Intentionally Left Blank**

**Table 6-1 Weight and Balance Worksheet**

		Weight(kg)	Arm (m)	Moment (Weight x Arm) (m.kg)
A)	Empty Aircraft			
B)	Pilot & Passenger		0.460	
C)	Baggage		1.210	
D)	Standard Fuel		1.115	
<b>Calculations</b>				
E)	Total Weight (A+B+C+D) =			
F)	Total Moment (A+B+C+D) =			
G)	Centre of Gravity (F/E) =			

## Use of Weight and Balance Table

### 1 Calculate the total loaded aircraft weight:

Empty weight (from the weight and balance sheet)

- Pilot and passenger
- Baggage
- Standard fuel

Ensure that total weight does not exceed 900 kg (1984 lb).

### 2 Input moments for the items of mass and then follow calculations in the second section to find the centre of gravity.

The resulting value must be within the centre of gravity moment envelope (Figure 6-1) for the load to be within limits.

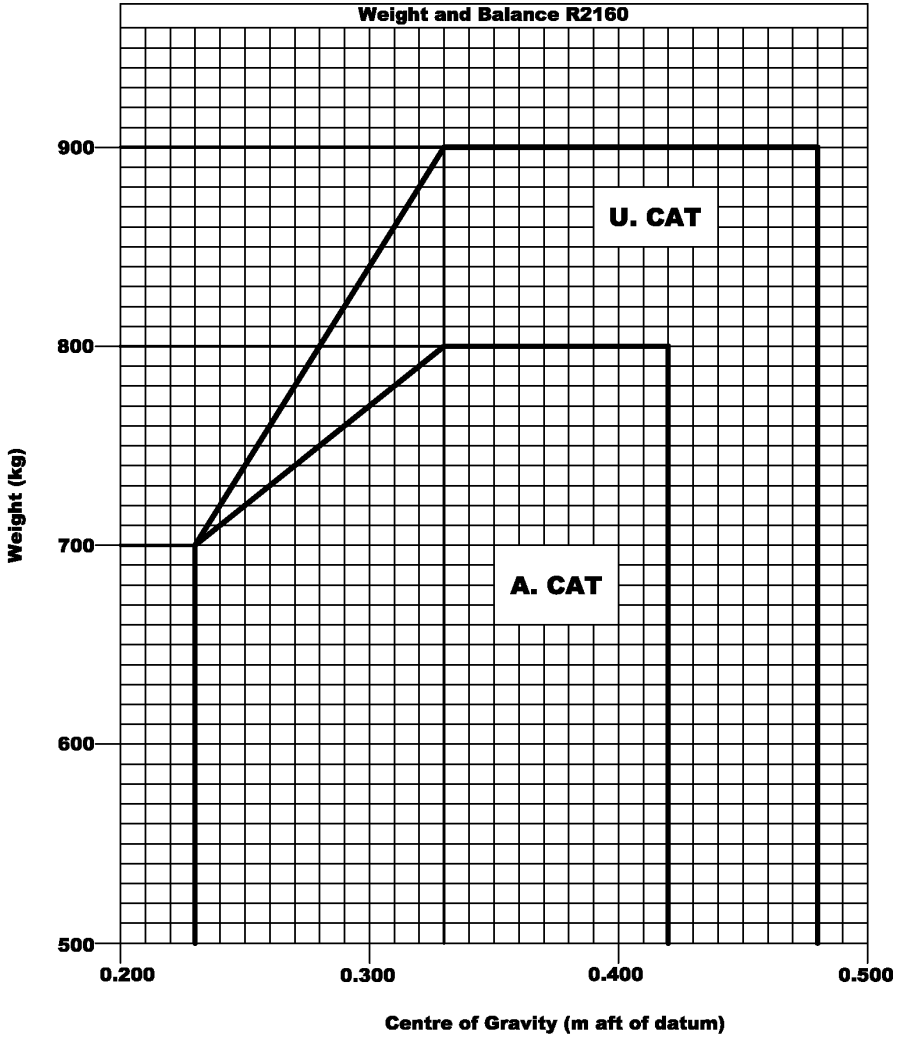

Figure 6-1 Weight and Balance Limits

**EXAMPLE**

Empty aircraft moment ..... (1063 ft.lb) 147 m.kg  
 Empty aircraft weight..... (1217 lb) 552 kg  
 Pilot and passenger ..... (154 lb) 70 kg  
 Fuel 60 l (13 imp/16 US gal)..... (95 lb) 43 kg  
 Baggage ..... (44 lb) 20 kg

		Weight(kg)	Arm (m)	Moment (Wt x Arm)
A)	Empty Aircraft	552		147
B)	Pilot & Passenger	70	0.460	32.2
C)	Baggage	20	1.210	24.2
D)	Standard Fuel	43	1.115	47.9
<b>Calculations</b>				
E)	Total Weight	(A+B+C+D) =	(552+70+20+43) =685	kg
F)	Total Moment	(A+B+C+D) =	(147+32.2+24.2+47.9) )=251.3	m.kg
G)	Centre of Gravity	(F/E) =	251.3/685 =0.367	m

1 litre AVGAS = 0.72 kg (1.6 lb)  
 1 imp gal AVGAS = 3.27 kg (7.2 lb)  
 1 US gal AVGAS = 2.7 kg (6 lb)

**\* ATTENTION**

*For your aircraft centre of gravity calculation, do not use values of empty aircraft weight and empty aircraft moment indicated in the above example! Use the values indicated in the last weight and balance sheet of your aircraft.*

## Fitted Equipment List

<b>Serial No:</b>	<b>Registration:</b>	<b>Date:</b>
-------------------	----------------------	--------------

**NOTE**

The installed equipment listed in this table has been included in the initial aircraft Weight and Balance carried out by the manufacturer.

Item No	Item	Mark if Installed	Weight (kg)	Arm (m)
1	Airspeed Indicator		0.3	0.47
2	Artificial Horizon		0.9	0.40
3	Altimeter		0.9	0.44
4	Optional Equipment			
	a. CDI (102A)		1.5	0.43
	b. CDI (106A)		1.6	0.43
5	Turn Coordinator		0.6	0.45
6	Directional Gyro		1.2	0.41
7	Vertical Airspeed		0.3	0.44
8	Tachometer		0.4	0.46
9	Optional Equipment			
	a. Altimeter (secondary)		0.9	0.44
	b. AD Indicator (KI227)		0.3	0.45
10	Fuel Flow/Pressure Gauge		0.3	0.45
11	Fuel Contents Gauge		0.3	0.45
12	Oil Pressure/Temperature Gauge		0.3	0.45
13	G Meter		0.3	0.44
14	Volt/Ammeter Gauge		0.3	0.45
15	a. Carburettor Temp/OAT (CA-1)		0.2	0.49
	b. EGT/CHT/OAT (EAC-1)		0.2	0.49
16	Vacuum Gauge		0.1	0.46
17	Compass		0.3	0.56
18	Super Clock		0.3	0.45
19	Voice Annunciator		0.6	0.11



# Section 7 : Description of Aircraft & Systems

## Contents

Airframe .....	7-3
Cabin .....	7-3
Engine .....	7-3
Propeller .....	7-3
Electrical System .....	7-4
Fuel System.....	7-6
Heating & Ventilation .....	7-8
Flight Controls.....	7-9
Instrument Panel.....	7-10
Specialised Instrumentation .....	7-13
FP5: Fuel Flow .....	7-13
SC-5 Super Clock.....	7-15
Voice Annunciator AV-17 .....	7-16
Artex ME-406 Emergency Locator Transmitter .....	7-18
EAC-1: EGT/OAT/CHT .....	7-19
OPT-1: Oil Temperature/Pressure .....	7-21
Garmin GMA 340 Audio Panel .....	7-23
Garmin GTX 327 Transponder .....	7-25
Garmin GNC250XL VHF Com / GPS Receiver.....	7-27
PS Engineering PMA4000 Audio Selector .....	7-28

**Page Intentionally Blank**

## Airframe

The Alpha R2160 is a low wing, tricycle undercarriage, acrobatic two seat trainer. It is an all metal design of conventional semi monocoque construction. The undercarriage is fitted with fairings to aid drag reduction.

Access to the cabin is via a built in step, hand grabs and a forward sliding bubble canopy.

## Cabin

The cabin has provision for pilot, passenger and luggage. The luggage deck has built in tie down points to secure the luggage.

The seats are adjustable fore and aft. A five point acrobatic harness is fitted as standard.

Cabin width	1.06 m (42")
Length	2.06 m (81")
Height	1.25 m (49")

## Engine

Lycoming O-320 D2A

160 BHP @ 2700 rpm

The engine is fitted with a carburettor and carburettor heat. An air/oil separator is fitted in the breather line terminating on the lower fuselage panel aft of the left step. Recovered oil is returned to the sump. A "Slick Start" magneto system is installed to improve starting. Also fitted is a "Skytech" light weight starter.

## Propeller

Sensenich metal propeller

74DM6S5-2-64

## Electrical System

The electrical system is conventional 14 volt with a GelCell lead acid battery and charged by an alternator of 60 Amp output. The system is protected by Circuit Breakers of varying capacity. A dual volt/ammeter is provided to monitor the electrical system.

The electrical system includes electrically actuated flaps, navigation lights, anti collision strobe lights, landing lights and cockpit/instrument lighting.

### ATTENTION

*The electrical system includes an Auxiliary Power socket, which is always live.*

*Ensure nothing is connected to this socket during take-off and landing.*

## Alternator Failure Warning Light

The “ALT FAIL” warning light on the annunciator panel is lit when the alternator is inoperative and the battery is providing power to the bus.

The “ALT FAIL” warning light is activated by the same system that activates the “DISCHARGE” LED on the VA/1A50 Voltmeter/Ammeter gauge.

## VA/1A50: Voltmeter / Ammeter

An E.I. Inc digital/analogue combined volt/ammeter is installed to monitor the electrical system.

The instrument is fitted with two warning lights which have the following function:

- Yellow “DISCHARGE” LED which indicates the alternator is inoperative and the battery is providing power to the bus.
- Red “HIGH VOLTS” LED illuminates when the bus voltage exceeds 15.3V.

## Cockpit and Instrument Light Controls

The cockpit and instrument lights are controlled via three dimmer controls on the annunciator panel and one dimmer on the centre console.

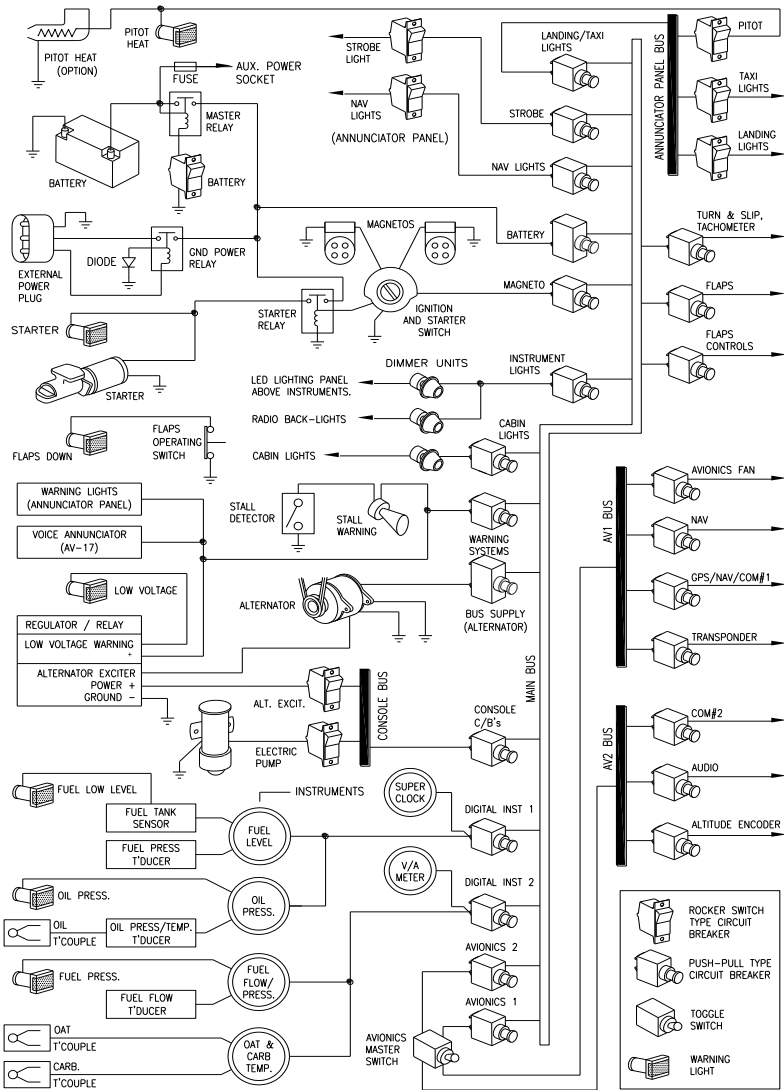

Electrical System Schematic

## Fuel System

The fuel system consists of a 160 litre tank mounted under the luggage deck and aft of the seat back. Fuel flows from the tank through a mesh finger strainer via a flexible line to the fuel shut off valve mounted on the lower fuselage skin. The shut off valve is actuated by a push/pull control mounted on the centre console.

From the shut off valve fuel flows to the adjacent electric fuel pump. This pump is at the lowest point in the system. The removable filter housing on the pump has been enlarged to provide an appropriate volume to trap any water or sediment in the system. A quick drain valve has been installed in the housing and permits water drain checks to be carried out during normal pre-flight walk round.

From the pump piping carries the fuel to the engine driven pump and then to the carburettor. The boost pump is actuated by a switch on the centre consol.

Two warning lights in the annunciator panel are provided for the fuel system. One advises low fuel pressure (Fuel Press) and the other low fuel level (Low Fuel Level). A fuel gauge is fitted to the lower sub panel and adjacent is a combined fuel flow/totaliser instrument. A calibrated dip stick is provided as an alternate method of determining fuel level. The dip stick is stowed in the baggage compartment.

The fuel system is schematically shown on the following page.

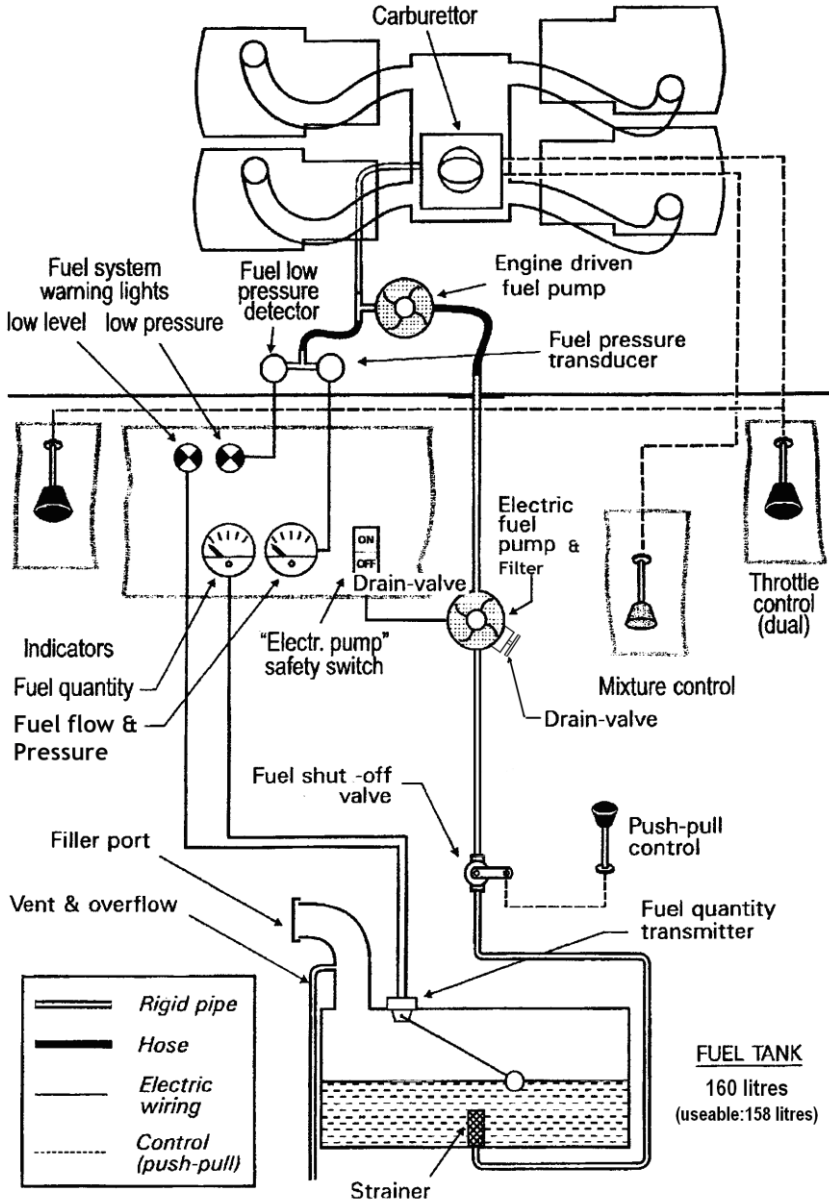

Fuel System Schematic

## Heating & Ventilation

Fresh air is provided by face level air vents integral with the instrument panel. Heating and demisting is also provided and selected by controls on the lower instrument panel.

The heat source is a heat box around the muffler. The hot air is directed by a heat control box on the firewall. This on/off control permits air to the heat distribution box which in turn can direct heated air to either the cabin or to the windscreen for demisting.

### HEATING AND VENTILATION SYSTEMS

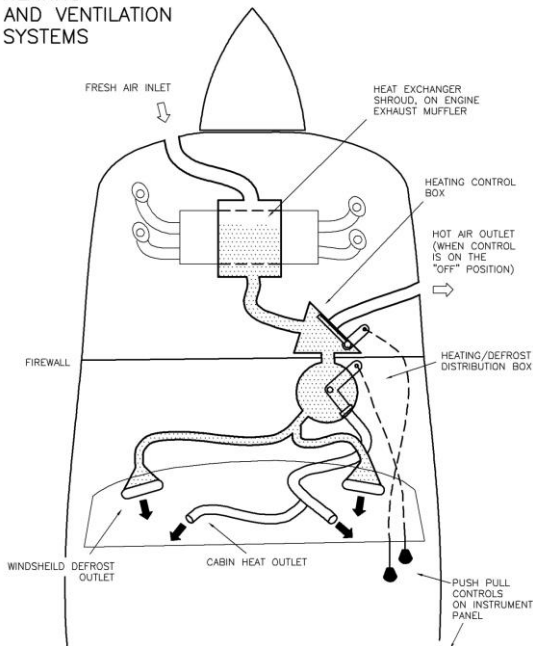

CABIN HEATING	○
PULL ON PUSH OFF	
CANOPY DEMIST	○
PULL OUT CABIN HEAT PUSH IN	

## Flight Controls

The aircraft is fitted with dual flight controls and can be flown from either the left or right hand seat. The control surfaces are of all metal construction and all are statically balanced. The control surfaces are operated by cables. In the case of the ailerons the cables operate a bell crank which in turn moves a push rod attached to the aileron. This arrangement provides for differential movement of the ailerons.

Pitch control is provided by a horizontal stabiliser fitted with anti-servo tabs. The pitch trim system is operated by a knurled trim wheel in the centre console and via a Telflex cable controls the angular relationship between the anti-servo tabs and the stabiliser.

The flaps are electrically actuated with three preset positions 0°, 10°, and 35° selected via a three position switch on the centre console. Flap position is shown on the indicator bar adjacent to the flap selector switch.

Nose gear steering is controlled by the rudder pedals.

# Instrument Panel

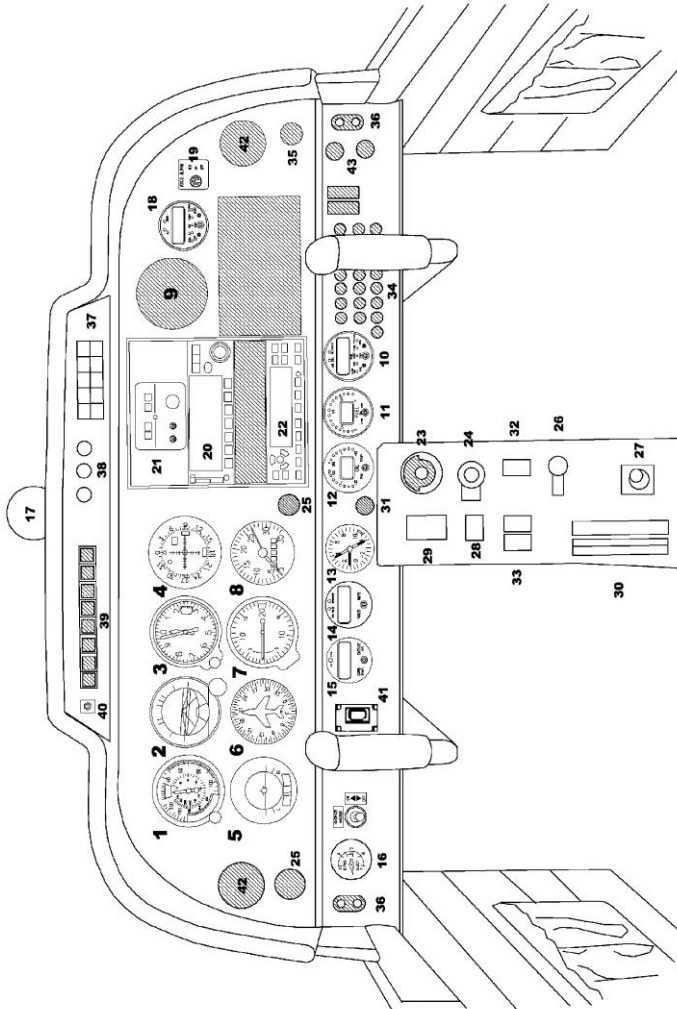

## Key to Panel Image

		2 <sup>nd</sup> Row	
1	Airspeed indicator	•	Magneto (Slick Start)
2	Gyro horizon	•	Console Lights
3	Altimeter	•	Flaps Power
4	Optional equipment	•	Flaps Control
5	Turn Coordinator	•	Digital Instruments 1
6	Directional gyro	•	Digital Instruments 2
7	Rate of climb indicator	•	Avionics 2
8	Tachometer	•	Battery
9	Optional equipment	•	Alternator
10	Fuel pressure/flow		
11	Fuel Quantity Indicator	3 <sup>rd</sup> Row	Warnings
12	Oil pressure/Temp	•	Altitude Encoder
13	G Meter	•	Com 2
14	Voltmeter/Ammeter	•	Audio
15	EGT/OAT/CHT	•	Nav
16	Vacuum gauge	•	GPS & Com 1
17	Magnetic compass	•	Transponder
18	Clock	•	Avionics Cooling Fan
19	Voice Annunciator Control Panel		
20	COM/NAV	35	Auxiliary Power Socket
21	Intercom	36	Mike/Headset Jack sockets
22	Transponder	37	Safety switches (from left to right):
23	Magneto selector switch with starter	•	landing lights
24	Mixture control	•	taxi light
25	Throttle controls	•	Strobe light
26	Carburettor heat control	•	navigation lights
27	Fuel shut off control	•	Spare
28	Flaps control lever	38	Panel lighting controls (from left to right):
29	Flaps Position indicator		
30	Elevator trim tab control wheel & Indicator	•	Panel lights (under glare shield)
31	Parking brake control	•	Cockpit lights (overhead flood lights)
32	Electric fuel pump switch		
33	Battery and alternator switch	•	Instrument / Radio
34	Circuit breakers (from left to right):	39	Warning Lamps (from left to right):
1 <sup>st</sup> Row		•	Low oil pressure
•	Turn & Slip	•	Low fuel pressure
•	Nav Lights	•	Low fuel level
•	Land/Taxi Lights	•	Low Volt
•	Strobe Lights	•	Starter
•	Cabin Lights	•	Flaps down
•	Instrument Lights	•	2 warning lamps    unused
•	Avionics 1	40.....	Warning lights test and .. dimming control
		41.....	ELT Remote Switch
		42.....	Cabin Fresh Air Vents
		43.....	Cabin Heat/Demist Controls

## Annunciator Panel

The annunciator panel contains:

Six warning lights:

- Low oil pressure
- Low fuel pressure
- Low fuel level
- Low Volt
- Starter
- Flaps down

Four safety switches:

- landing lights
- taxi light
- Strobe light
- navigation lights

Four panel lighting controls:

- Warning light DAY/NIGHT/TEST
- Instrument panel dimmer
- Overhead light dimmer
- Instrument / Radio light dimmer

### Warning Light Description:

OIL PRESS:	Illuminates RED when the oil pressure drops below 25 psi
FUEL PRESS:	Illuminates RED when the fuel pressure drops below 0.5 psi.
LOW FUEL:	Illuminates RED when the fuel level drops below 20 litres.
LOW VOLT:	Illuminates YELLOW when the battery voltage drops below 13V.
STR:	Illuminates RED when the starter is activated.
FLAPS DOWN:	Illuminates GREEN when the flaps are extended.

## Specialised Instrumentation

### FP5 : Fuel Flow / Fuel Pressure

An *Electronics International Inc.* FP5 fuel flow/pressure instrument is fitted to the sub panel in this aircraft.

The fuel flow has been set at the factory to indicate the flow in litres/hour, the fuel quantity in litres and the fuel pressure in PSI. For more information on various operations and use of different units refer to the latest edition of the "Operating Instructions" P/N OI 050593P.

The instrument controls are as follows:

1. Low Fuel Warning LED.
2. High/Low Pressure Warning LED.
3. Display Mode Indicator LED's.
4. Left "PRG" (Program) button.
5. "STEP" switch.
6. Right "PRG" (Program) button.

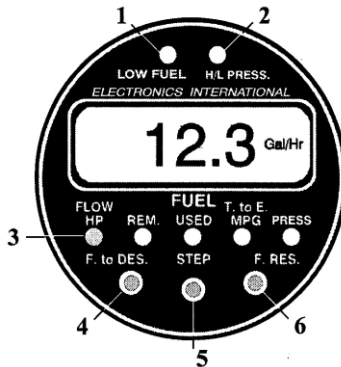

On power up note the following:-

1. When the master is turned on the fuel flow will display the theoretical fuel remaining in the tank if the added fuel has been updated.
2. The green "REM" led and the red "High/Low Fuel Pressure Warning" led are blinking as a reminder to update the fuel quantity.
3. To change the fuel remaining perform the following steps:
  - Check that "REM" mode is selected
  - Momentarily push both "PRG" buttons at the same time
  - The display will show "ADD"
  - Push either one of the "PGR" buttons
  - The display will show the current fuel remaining. The blinking left digit indicates that you may programme this digit first
  - Advance the digit count. Moving the mode select switch to the right will increase the blinking digit by one
  - Increase next digit by pushing a "PGR"
  - To exit the "ADD" programming mode press both "PGR" buttons
4. Select the display mode to "FLOW"

#### NOTE

***It is imperative the pilot verify the calibration of the FP-5 over many tanks of fuel before using the "REM" and/or "USED" modes as an***

***indication of the fuel remaining or fuel used. Even after verifying the calibration of the FP-5 it should never be used as the primary indicator of fuel quantity in the tanks.***

## SC-5 Super Clock

The SC-5 is a multi purpose timing device. Apart from the usual timing functions it also monitors engine time. There are five display modes as follows:

1. "LOCAL" Clock – this mode displays local time in either 12 or 24 hr format.
2. "ZULU" Clock – this mode displays Zulu time.
3. "UP" Timer – in this mode the timer counts up automatically from when the "Master" is turned on, acting as a flight timer. Alarms may also be programmed in to alert the pilot at chosen intervals.
4. "DN" Timer – in this mode the timer counts down. The start time can be set as required and when the timer reaches 0:00 a yellow warning LED will blink.
5. "ENGINE TIME" – in this mode the SC-5 acts as a "Hobbs" meter and displays the total time the engine has been running. It is not possible to reset this timer.

On start up (master switch on) the SC-5 performs a self diagnostic test, displaying "88:88" and flashing the yellow warning LED's.

The SC-5 face is shown below indicating warning LED and button locations.

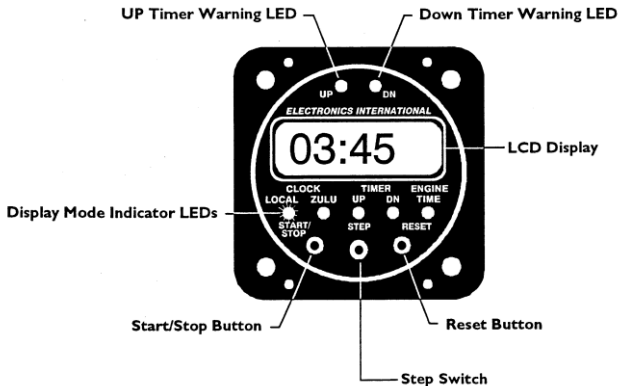

For instructions on set up and using the functions refer to Electronics International Operating Instruction OI 0313961 latest issue.

## Voice Annunciator AV-17

### General Description

This aircraft is equipped with a voice annunciator which warns the pilot when certain limits have been exceeded. The annunciator is wired through the audio panel and gives voice messages to the pilot. The unit is controlled by a small control panel mounted on the co-pilots instrument adjacent to the SC-5 clock.

This panel allows the pilot to acknowledge (and thereby deactivate the alarm temporarily) or turn the Voice Annunciator off

The AV -17 is a voice Annunciator packaged in a 4.1" by 2.6" by 1.7" control box located under the right hand side of the instrument panel. There is also a small remote control switch mounted on the right side of the main instrument panel.



### Control Panel

The control panel allows you to turn the AV-17 ON or OFF. Also, it allows you to acknowledge and thereby deactivate any active alarm to either 1 minute or 10 minutes.

The AV-17 is connected to the aircraft speaker system. The AV-17 is capable of providing AURAL warnings relating to 18 different events. Additionally, a **"Check Bus Voltage"** warning is built into each AV-17.

### NOTE:

Only the warnings listed below are in service on this aircraft and they are listed in order of priority:

1. Airspeed
2. Oil Pressure
3. Oil Temperature
4. Fuel Level
5. Fuel Pressure
6. Bus Voltage

Immediately any of the pre-set parameters are exceeded the Voice Annunciator will chime through the speaker and a female voice will announce the appropriate warning with a phrase, such as: **"Check Oil Pressure,"** or **"Check Airspeed"** etc.

If two or more alarms are activated, the alarms are placed on the AV-17's "Task List" and are announced one at a time with a one second delay between alarms. After the last alarm on the list is announced there is a five second delay and the alarms are once again announced in order.

### Power - up Announcement

When power is applied to the AV-17 and the control panel switch is placed in the on position, the unit will announce **"Voice Annunciator Enabled. Have a nice flight"**. This announcement will be made only once, at the beginning of each flight.

### Acknowledging and Silencing an Alarm

An activated alarm can be silenced by momentarily moving the switch on the AV-17 to the "ACK" position; a high pitch tone will be heard through the speaker and all **active alarms** will be silenced for one minute. By moving the switch to the "ACK" position three times within three seconds the **active alarms** can be silenced for ten minutes.

**Turning the AV-17 “OFF”**

To disable the AV-17, silence all voice alarms through the speaker and reset any delay times, set the control panel switch to the “OFF” position. When the AV-17 is once again set to the “ON” position the AV-17 will announce “Voice Annunciator Enabled” This will be followed by any active alarms.

**NOTE**

It is the responsibility of the Pilot in Command to ensure that he has read and fully understands the information contained in the instrument manufacturers installation and operations manual for correct operation of the AV-17 Voice Annunciator prior to embarking on any flight.

## **Artex ME-406 Emergency Locator Transmitter**

### **Description:**

The Artex ME-406 is a single output Non-Portable type Emergency Locator Transmitter (ELT). Two emergency frequencies (121.5 and 406.028 MHz) utilize the Radio Frequency (RF) output, which requires only one coax cable to connect to the new series of Artex single output antennas.

### **Location**

The ELT is located in the rear fuselage section of the aircraft and is attached by bracket to the floor section on the starboard side of the aircraft.

### **Operation**

In the event of a crash, the ELT automatically activates and will transmit the standard sweep tone on 121.5 MHz. Every 50 seconds for 440 milliseconds and the 406 MHz transmitter turns on and transmits an encoded digital message to the Cospas/Sarsat satellite system.

### **Remote Switch**

A three position (ON/ARM/RESET) remote switch is located on the instrument Panel, this gives the pilot or maintenance provider the ability to control the ELT manually if required.

The Artex ME-406 ELT is accurate to within Three (3) Kilometres

## EAC-1: EGT/OAT/CHT



2 1/4" Mount, 2.5" Depth,  
Weight 16 Oz.  
STCd, TSOd, PMAd,  
1 Degree Resolution,  
Accurate within 1/2%,  
Viewable in direct sunlight

### Description:

The EAC-1 instrument fitted in this aircraft is a combination "single channel" Exhaust Gas Temperature (EGT), Cylinder Head Temperature (CHT) and Outside Air Temperature gauge (OAT). The Pilot is able to monitor the above functions by manipulating the 3 way toggle switch on the face of the instrument to the desired position, this will result in the appropriate information being displayed in digital format on the LCD display located in the centre of the instrument.

### Exhaust Gas Temperature (EGT)

The Exhaust Gas Temperature (EGT) is directly related to the combustion temperature, it is an indication of the engine's ability to produce power. With correct use of the mixture control, the pilot is able to establish by monitoring the EGT when the engine is operating at an optimum for that particular condition of flight.

### Cylinder Head Temperature (CHT)

The Cylinder Head Temperature (CHT) instrument helps the pilot protect the engine against the threat of excessive heat. Most general aviation aircraft monitor the hottest CHT, as determined by extensive flight test done by the aircraft manufacturer.

Shock cooling of the engine is also a problem that is common with aircraft engines, this is caused by rapid descents with little or no power and excessively rich mixtures.

**Outside Air Temperature (OAT)**

The probe for this instrument is located approximately mid-point in the outboard section on the underside of the Port wing. This particular instrument is very sensitive and it is for this reason, when the aircraft is stationary on a hot surface, such as Asphalt or concrete the unit will read the actual temperature to which it is exposed. Once removed from the heat source the temperature readings will rapidly change to read ambient temperature.

**Ice Zone Warning Light**

This light will come on when the Outside Air Temperature drops to + 4°C and stays above - 12°C.

This feature can be very useful for warning the pilot of the possibility of structural ice if the prevailing conditions are right, it is independent of the other functions of this instrument

**NOTE:**

Pilots must familiarise themselves with the engine manufacturers recommended procedures when leaning the aircraft engine, failure to follow the correct procedures could result in damage to the engine and possible engine failure. It is advised that all "Normal" and "Non Normal" operating temperatures and pressures and the corresponding instrument markings on this aircraft are noted prior to embarking on any flight.

## OPT-1: Oil Temperature/Pressure Gauge



For Illustration Purposes only, refer to gauge in aircraft for correct markings.

### Features:

- Dual 90 degree graphic analog displays with green, yellow, and red LED's.
- Accurate digital display. 1 PSI and 1°F Resolution. Remote oil pressure and temperature transducers.

### Specifications:

- 2 1/4" Mount. 3.65" Depth. 22 Oz. Kit.
- Viewable in direct sunlight.
- Backlit for night operation.
- Operates from 7.5 to 35 volts at .3 amps.

### \*\*Important Information\*\*

**Note:** This instrument designates any "Caution Range" with yellow LED's, the "Maximum and Minimum Limits" each with a red LED, and the "Safe Operating Range" with green LED's. The "Safe Operating Range" on this instrument is equivalent to an analog gauge's green "Normal Operating Range"

The Pressure range is marked with a Red LED on the low end followed by a Yellow Caution LED and then green LED's up to a high end Yellow LED followed by the "Maximum Temperature Limit." Red LED

The Temperature range is marked with a yellow LED on the low end and green LED's up to the "Red LED Maximum Temperature Limit."

**NOTE:**

**For full instructions on the operation of the OPT 1 Oil Pressure/Temperature Gauge refer to the manufacturers "Operating and Installation Instructions Manual"**

It is the responsibility of the Pilot in Command to ensure that he has read and fully understands the information contained in the "Operating and Installation Instructions Manual" for correct operation of the OPT 1 Oil Pressure/Temperature Gauge prior to embarking on any flight.

## Garmin GMA 340 Audio Panel (where fitted)

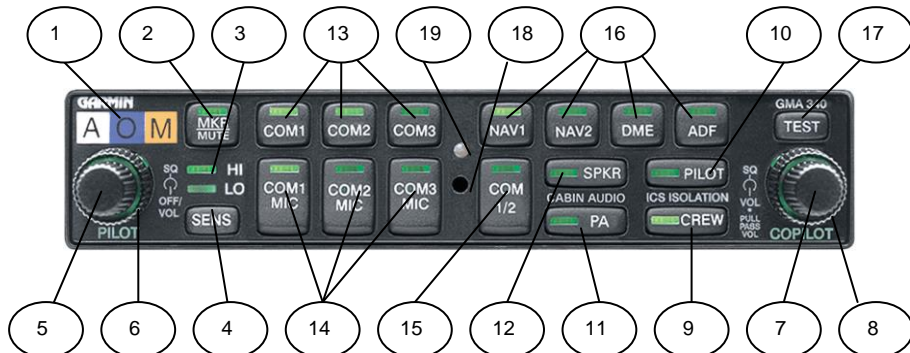

### Function Selection Switches

The left small knob (5, 7) controls the ON/OFF function.

### Marker Beacon

1. Marker Beacon Lamps
2. Marker Beacon Receiver Audio Select/Mute Button
3. Marker Beacon Receiver Sensitivity Indicator LED's
4. Marker Beacon Receiver Sensitivity Selection Button

### Pilot Intercom System (ICS)

5. Pilot Intercom System (ICS) Volume
6. Pilot ICS Voice Activated (VOX) Intercom Squelch Level
7. Copilot and passenger ICS Volume 1/2 Control (Pull out for Passenger Volume)
8. Copilot and Passenger VOX Intercom Squelch Level
9. Crew Isolation Intercom Mode Button
10. Pilot Isolation Intercom Mode Button
11. Passenger Address (PA) Function Button
12. Speaker Function Button

### Communication & Navigation

13. Transceiver Audio Select Buttons (COM 1, COM 2, COM 3)
14. Transmitter (Audio/Mic) Selection Buttons
15. Split COM Button
16. Aircraft Radio Audio Selection Buttons (NAV 1, NAV 2, DME, ADF)
17. Annunciator Test Button
18. Locking Screw Access
19. Photocell – Automatic Annunciator Dimming

**NOTE:**

**For full instructions on the operation of the GMA 340 refer to the manufacturers "Pilots Guide"**

It is the responsibility of the Pilot in Command to ensure that he has read and fully understands the information contained in the "Pilots Guide" for correct operation of the GMA 340 Audio Panel prior to embarking on any flight.

## Garmin GTX 327 Transponder



The Garmin GTX 327 Transponder is powered by pressing the **STBY**, **ALT** or **ON** keys. Or by a remote avionics master switch (if applicable). After power on, a start-up page is displayed while the unit performs a self test. If the unit detects an internal failure, the screen displays SELF TEST FAILED. (See your GARMIN Dealer for Software Upgrades)



### Mode Selection Keys

**OFF** – Powers off the GTX 327. Pressing **STBY**, **ON** or **ALT** Key powers on the transponder displaying the last active identification code.

**STBY** – Selects the standby mode. When in standby mode, the transponder will not reply to any interrogations.

**ON** – Selects Mode A. In this mode, the transponder replies to interrogations, as indicated by the reply Symbol ®. Replies do not include altitude information.

**ALT** – Selects Mode A and Mode C. In **ALT** mode, the transponder replies to identification and altitude interrogations as indicated by the Reply Symbol ®. Replies to altitude interrogations include the standard pressure altitude received from an external altitude source, which is not adjusted for barometric pressure. The **ALT** mode may be selected in aircraft not equipped with an optional altitude encoder; however, the reply signal will not include altitude information.

Any time the function **ON** or **ALT** is selected the transponder becomes an active part of the Air Traffic Control Beacon System (ATCRBS). The transponder also responds to interrogations from TCAS equipped aircraft.

### NOTE:

**For full instructions on the operation of the GTX 327 refer to the manufactures “Pilots Guide”**

It is the responsibility of the Pilot in Command to ensure that he has read and fully understands the information contained in the "Pilots Guide" for correct operation of the GTX 327 Transponder prior to embarking on any flight.

## Garmin GNC250XL VHF Com / GPS Receiver

The GNC 250XL System is a fully integrated panel mounted instrument, which contains a 760 channel VHF Communications transceiver and Global Positioning System (GPS) Navigation computer. The system consists of an antenna and a receiver in its mounting rack. The primary function of the VHF Communication portion of the equipment is to facilitate communication with Air Traffic Control. The primary function of the GPS portion is to acquire signals from the GPS satellites, recover the orbital data, make range and Doppler measurements, and process this information in real-time obtain the user's position, velocity, and time.

Provided that the Garmin GNC 250XL navigation system is receiving adequate usable signals, it has been demonstrated of and has been shown to meet the accuracy specifications of FAA Advisory Circular 20-138 for VFR flight.

Navigation is accomplished using the WGS-84 (NAD-83) co-ordinate reference datum. Navigation data is based upon use of only the Global Positioning System (GPS) operated by the United States of America.

It is the responsibility of the Pilot in Command to ensure that he has read and fully understands the information contained in the "Pilots Guide & Reference" for correct operation of the GNC 250XL VHF Com / GPS prior to embarking on any flight.

## PS Engineering PMA4000 Audio Selector (where fitted)

(where fitted)



The PMA4000 is a 4-place with added capability for communications navigation receivers, as

speaker amplifier. The intercom features PS Engineering's individual volume controls for both the pilot and copilot.

panel mounted intercom switching two transceivers and well as providing a

speaker amplifier. The intercom features PS Engineering's exclusive IntelliVox® with individual volume controls for both the pilot and copilot.

- A multi-position mode switch allows the pilot to select either Pilot Isolate or All intercom modes.
- The ISO mode isolates the pilot from the intercom, and connects directly with the aircraft radios. The copilot and passengers are free to have conversation and enjoy the entertainment without radio interruption. The pilot is not distracted by passenger intercom use and has control over the radio communications.
- The "ALL" mode places everybody on a party line. Each person hears all intercom conversation and aircraft radio reception. Everyone hears the entertainment source as well.
- The "Off" mode is part of the automatic fail-safe interconnect to the aircraft systems. If power to the intercom is disrupted, the pilot's headset is automatically connected to the aircraft radio. This permits continuous radio communications.

The PMA4000 has independent intercom volume controls for the pilot, and the copilot. Because this system was designed with the tandem cockpit in mind, the copilot volume can be remote-mounted in another location. Because the pilot and copilot volume control does not affect the aircraft radio volume, balance between the intercom and radio audio is easily achieved. For instance, by reducing the pilot's intercom volume, the aircraft radio volume will be in the foreground, while the intercom will be at a background level.

The PMA4000 IntelliVox® intercom squelch system eliminates complicated squelch adjustments. In addition, by using independent microphone circuits unwanted noise is kept out of the audio. Since only the microphone being spoken into is open, extraneous cabin noise is minimized. Individual squelch controls mean that the system can be tailored to different microphones, as well as variations in voice levels in the cockpit.

The PMA4000 has two switched com transceiver inputs and two switched navigation receiver inputs. In addition, there are four un-switched audio inputs that can be used for other receivers or audio warnings such as autopilot disconnect or GPS alerts.

There is a built in speaker amplifier in the unit. Pushing the volume control will place all selected audio, or any un-switched audio present, over a cabin speaker.

With the PMA4000 installed, both pilot and copilot have transmit capability over the aircraft radios. Only the person who presses the PTT is heard over the radio. The

selected com LED shows green when selected, and flashes during radio transmissions. This feature acts as a stuck microphone indication.

The COM transceiver switching is automatic. When the toggle switch microphone selector is in COM 1, the receive audio and microphone signals are both presented to the audio. The push button selector controls receive audio only, and is used to select multiple com receivers.

### **NOTE**

It is the responsibility of the Pilot in Command to ensure that he has read and fully understands the information contained in the instrument manufacturers installation and operations manual for correct operation of the PMA4000 Audio Selector prior to embarking on any flight.

**Page Intentionally Blank**

# **Section 8 : Handling, Servicing & Maintenance**

## **Contents**

Ground Handling	8-3
Mooring	8-3
Routine Maintenance	8-3

**Page Intentionally Blank**

## Ground Handling

To enable the aircraft to be moved by hand without pushing on the airframe, a tow bar is provided. When steering the aircraft with the tow bar care should be taken to ensure the limit stops are not forced.

### **NOTE**

*The outer two thirds of the propeller and/or spinner should not be used to push against while manoeuvring the aircraft.*

## Mooring

Mooring points are provided under the wings near the tips. The third point is the tail spring fitting. When mooring, the controls should be prevented from moving by utilising the lap straps to secure the control stick. Care should be taken to ensure the controls are not forced by using only sufficient tension to prevent movement of the surfaces in the wind.

## Routine Maintenance

This aircraft is to be maintained in accordance with section 3 of the R2000 Service Manual.

Pilot maintenance may be permitted if the Rules of the Civil Aviation Authority of the country in which the aircraft is operated provides for such maintenance.

**Page Intentionally Blank**

# Section 9 : Supplements

## Contents

### STANDARD SUPPLEMENTS

<b>Title</b>	<b>Incorporated</b>
Operation of Aircraft without wheel spats	* (AA 06/2006)

### ADDITIONAL SUPPLEMENTS

<b>Title</b>	<b>Incorporated</b>
Modification AA/60/0412 Installation Standard Instruments	
Modification AA/60/0413 Installation of Instruments and Safety Equipment	
Modification AA/60/0415 Installation of Standard Instruments	
Modification AA/60/0717 Installation of 110 Litre Ferry Fuel System	
Modification AA/60/0774 Installation of Instruments	
Modification AA/60/0870 Installation of Analogue Instruments	
Modification AA/60/1127 Fuel Systems	
Supplement AA/60/1127 Replacement Rocker Switches (AA-SB-24-003)	

CAA Approved AFM Supplements must be in the airplane for flight operations when the subject optional equipment is installed or the special operations are to be performed.

**Page Intentionally Blank**

# **160A FLIGHT MANUAL SUPPLEMENT**

## **OPERATION OF AIRCRAFT WITHOUT WHEEL SPATS**

CAA approved supplementary information.

**Page Intentionally Blank**

# 160A FLIGHT MANUAL SUPPLEMENT

## OPERATION OF AIRCRAFT WITHOUT WHEEL SPATS

### List of Effective Pages

Page Number	Revision date
1	December 2006
2	December 2006
3	December 2006
4	December 2006

**SECTION 1- GENERAL**

Removal of the wheel spats is permitted.

Information in this document supplements or supersedes information in the basic Aircraft Flight Manual. For limitations, emergency procedures, normal procedures and performance information not contained in this supplement refer to the basic CAA approved Flight Manual.

**SECTION 2- LIMITATIONS**

Unchanged.

**SECTION 3- EMERGENCY PROCEDURES**

Unchanged.

**SECTION 4- NORMAL PROCEDURES**

Unchanged.

**SECTION 5- PERFORMANCE****Take off performance**

The 50 ft (15 m) clearance distance must be increased by 2.1%.

**Climb Performance**

The climb rate must be decreased by 2%.

**Cruise Performance**

Level flight speeds must be decreased by 6%.

**SECTION 6- WEIGHT & BALANCE**

The empty weight must be decreased by the weight of the wheel spats.

The movement of the Centre of Gravity is insignificant.